

MICROMETERS

- **METROLOGY**® micrometers come in brand new designs. Each model is uniquely made with new quality in innovations, function and precision. They are the ultimate market value you will find. We are confident that our products will fully satisfy your demand and earn your trust.
- Each of our brand new designed micrometers is developed in Taiwan. Innovated design combines with the workmanship of German parts. 100% quality control assurance is carried out in our calibration laboratory in Taiwan.
- Metrology micrometers are made with hardened cast iron and steel. Precision spindle, screw and measuring anvil are precision grinded and polished to ensure the requirements for absolute flatness, parallels, and rigidity.
- Each micrometer is calibrated based on the standards of ISO 2012, DIN 863 in Germany, JIS B7502 in Japan and JCC (Jingstone Calibration Center) in Taiwan. English certificates included.

EXTERNAL MICROMETERS ACCURACY STANDARDS

DIN 863

JIS B7502

Measurement Length(mm)	Accuracy limits	Parallelism of the measuring face		Deformation*2	Flatness of Measuring face	Parallelism of measuring face	Instrument Error	Deflection of frame load of 10 N *2				
		*1	um									
0-25	4	6	2	2	0.6	2	±2	2				
25-50	4	6	2	2				3	±3	3		
50-75	5	10	3	3						4	±4	4
75-100	5	10	3	3								5
100-125	6	-	3	4		6	±6	6				
125-150	6	-	3	5				7	±7	7		
150-175	7	-	4	6		8	±8			8		
175-200	7	-	4	6				9	±9	9		
200-225	8	-	4	7		10	±10			10		
225-250	8	-	4	8				11	±11	11		
250-275	9	-	5	8		12	±12			12		
275-300	9	-	5	9				13	±13	13		
300-325	10	-	5	10		14	±14			14		
325-350	10	-	5	10				15	±15	15		
350-375	11	-	6	11	1	±16	16					
375-400	11	-	6	12			6	±17	17			
400-425	12	-	6	12	7	±18			18			
425-450	12	-	6	13			8	±19	19			
450-475	13	-	7	14	9	±20			20			
475-500	13	-	7	15								

*1. Number of interference rings or lines

*2. Acceptable stability deformation from a measurement force of 10N

UNIT: 0.001mm

BUNDESREPUBLIK DEUTSCHLAND

URKUNDE

über die Eintragung des

Gebrauchsmusters

Nr. 202 18 796.9

IPC: G01B 3/18

Bezeichnung:
Mikrometer

Automatic measuring pressure force

Gebrauchsmusterinhaber:
Tzeng, Lee-Ching, Kaohsiung, TW

Tag der Anmeldung: 04.12.2002

Tag der Eintragung: 10.04.2003



**Design in Taiwan
Patented in Germany**

Der Präsident des Deutschen Patent- und Markenamts

Dr. Schade

Dr. Schade

Digital Outside Micrometer (Standard)



Large, high contrast LCD display, resolution 0.001mm/ 0.00005"

per revolution 0.5mm

Spindle lock

German technique unibody precision screw and Φ 6.5mm spindle

Tungsten carbide anvil

Thimble and screw lock device

German patented ergonomic design thimble with automatic pressure force

Function button
 ON/OFF : power on/off
 SET : setting zero at any positions
 ABS/INC : ABS/INC value conversion
 in/mm : imperial and metric conversion

Painted cast iron frame

Heat insulating plastic frame cover

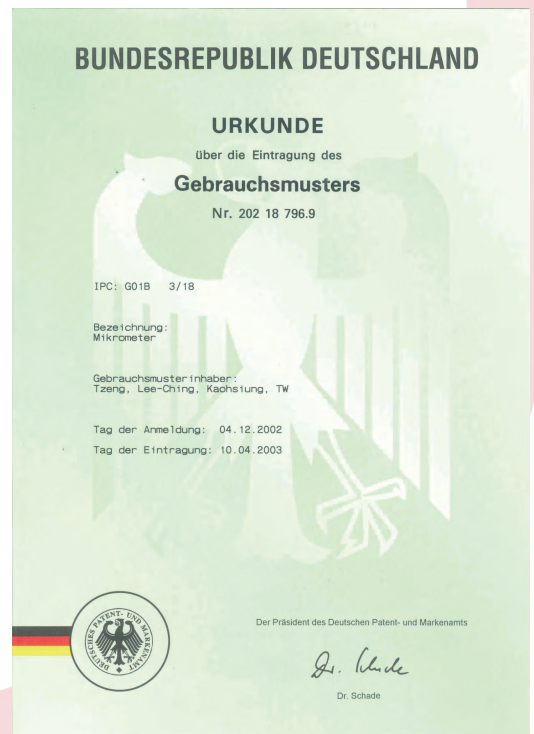

Model No.	Measuring Range	Accuracy
EM-9001	0-25mm / 0-1"	±3um
EM-9002	25-50mm / 1"-2"	±3um
EM-9003	50-75mm/ 2"-3"	±4um
EM-9004	75-100mm / 3"-4"	±4um

- Above 25mm models include one setting standard bar
- All models include warranty card, manual, and JCC calibration certificate

Digital Outside Micrometer (IP65)



Chrome laser engraved graduation sleeve

per revolution
0.5mm

Large, high contrast LCD display,
resolution 0.001mm/ 0.00005"

Spindle lock

German patented ergonomic
design thimble with
automatic pressure force

German technic unibody
precision screw and Φ 6.5mm
spindle

Chrome laser engraved
graduation thimble

Tungsten
carbide anvil

Function button
ON/OFF : power on/off
in/mm : imperial and metric conversion
ZERO : setting zero at any positions

Painted cast
iron frame

Heat insulating
plastic frame cover

IP65 dust/water protection

Model No.	Measuring Range	Accuracy
EM-9001SF	0-25mm / 0-1"	$\pm 3\mu\text{m}$
EM-9002SF	25-50mm / 1"-2"	$\pm 3\mu\text{m}$
EM-9003SF	50-75mm / 2"-3"	$\pm 4\mu\text{m}$
EM-9004SF	75-100mm / 3"-4"	$\pm 4\mu\text{m}$

Optional accessories:

Data output cable(DO-B+C01) · Bluetooth wireless data transmitter(DO-W2-RS1)

- Above 25mm models include one setting standard bar
- All models include warranty card, manual, and JCC calibration certificate



Digital Outside Micrometer (IP65 Fast)



per revolution 2 mm

Chrome laser engraved graduation sleeve

IP65 water/dust protection

Spindle lock

German technic unibody precision screw and Φ 6.5mm spindle

Tungsten carbide anvil

Thimble and screw lock device

German patented ergonomic design thimble with automatic pressure force

Function button

ON/OFF : power on/off
 SET : setting zero at any positions
 ABS/INC : ABS/INC value conversion
 UNIT : imperial and metric conversion

Painted cast iron frame

Large, high contrast LCD display, resolution 0.001mm/ 0.00005"

Heat insulating plastic frame cover

BUNDESREPUBLIK DEUTSCHLAND

URKUNDE
 über die Eintragung des
Gebrauchsmusters
 Nr. 202 18 796.9

IPC: G01B 3/18

Bezeichnung:
 Mikrometer

Gebrauchsmusterinhaber:
 Tzeng, Lee-Ching, Kachung, TW

Tag der Anmeldung: 04.12.2002

Tag der Eintragung: 10.04.2003



Der Präsident des Deutschen Patent- und Markenamts

Dr. Schade

Model No.	Measuring Range	Accuracy
EM-9001WF	0-25mm / 0-1"	$\pm 3\mu\text{m}$
EM-9002WF	25-50mm / 1"-2"	$\pm 3\mu\text{m}$
EM-9003WF	50-75mm / 2"-3"	$\pm 4\mu\text{m}$
EM-9004WF	75-100mm / 3"-4"	$\pm 4\mu\text{m}$

- Above 25mm models include one setting standard bar
- All models include warranty card, manual, and JCC calibration certificate

Digital Outside Micrometer (IP65 Second)



Function buttons
 ⏻ : power on/off
 ABS/0 : ABS/INC value conversion setting zero at any positions
 in/mm : imperial and metric conversion
 ORIGIN: absolute zero



Model No.	Measuring Range	Accuracy
EM-9001S	0-25mm / 0-1"	±3um
EM-9002S	25-50mm / 1"-2"	±3um
EM-9003S	50-75mm/ 2"-3"	±4um
EM-9004S	75-100mm / 3"-4"	±4um

Optional accessories:

Data output cable(DO-B+C04) · Bluetooth wireless data transmitter(DO-W2-RS1)

- Above 25mm models include one setting standard bar
- All models include warranty card, manual, and JCC calibration certificate

Digital Outside Micrometer (IP65 Second)



Model No.	Measuring Range	Accuracy	Model No.	Product
EM-9001SA	0-25mm / 0-1"	±3um	EM-12A EM-34A	Universal stand
EM-9002SA	25-50mm / 1"-2"	±3um		
EM-9003SA	50-75mm / 2"-3"	±4um		
EM-9004SA	75-100mm / 3"-4"	±4um		



- Model SA include micrometer and universal clamp stand
- Above 25mm models include one setting standard bar
- All models include warranty card, manual, and JCC calibration certificate

Vernier Outside Micrometer (General Features)

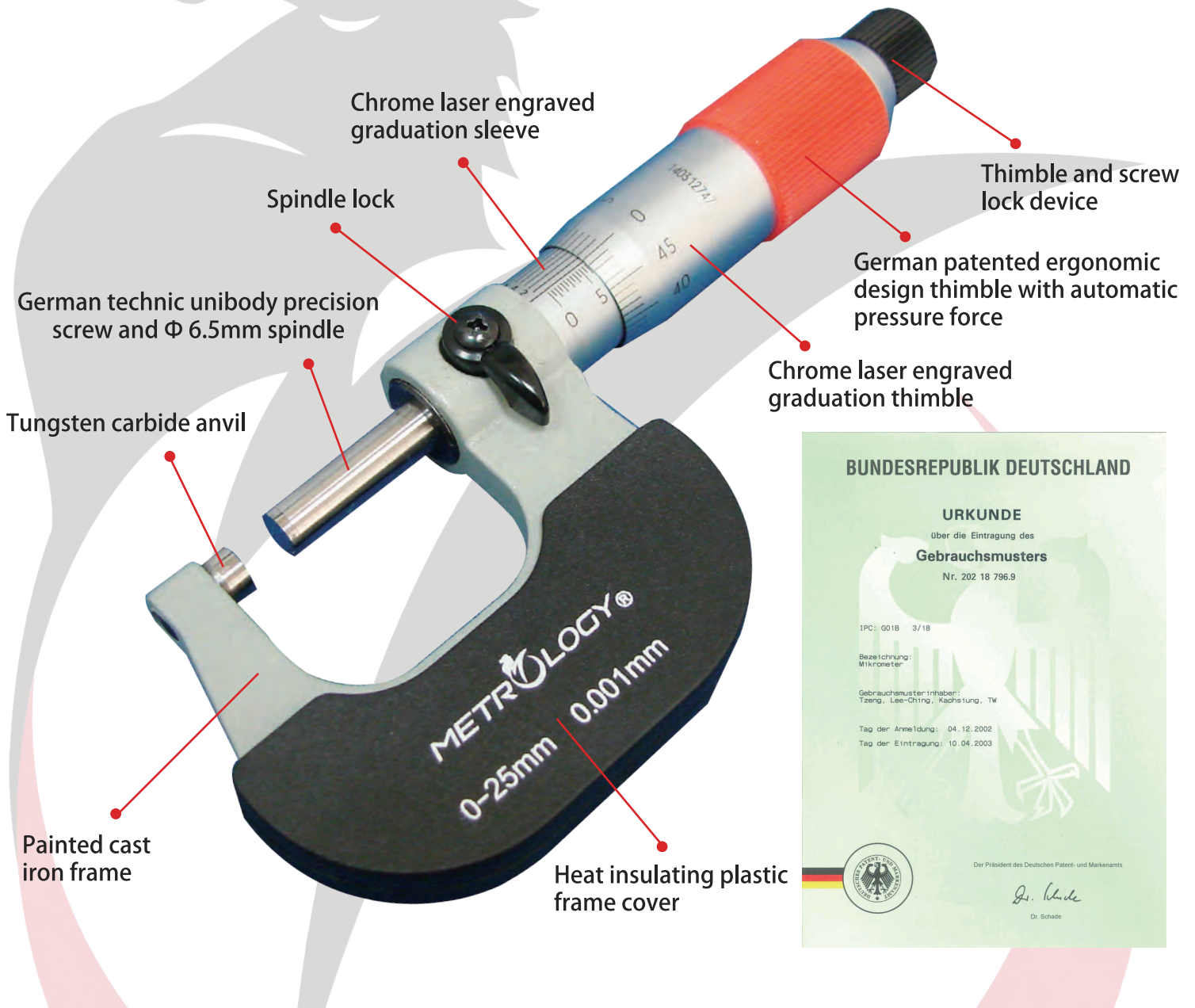

Scale Graduation

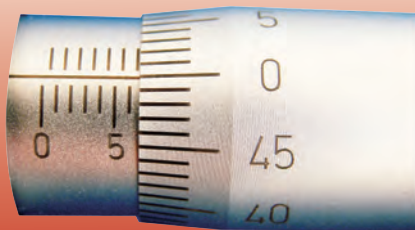

$$\begin{array}{r} 6 \\ 0.5 \\ + 0.00 \\ \hline 6.50 \text{ mm} \end{array}$$



$$\begin{array}{r} 6 \\ 0.00 \\ + 0.000 \\ \hline 6.000 \text{ mm} \end{array}$$

- Above 25mm models include one setting standard bar
- All models include warranty card, manual, and JCC calibration certificate

Digital Outside Micrometer (Special anvil types general features)



Button Functions

ON/OFF : Switch On and Off

SET : Setting zero at any positions

ABS/INC : Absolute and Increment value conversion

UNIT : Imperial and Metric conversion

↻ : Data output

RS232 Interface output

IP54 Water/dust protection

1.5V LR44 battery

- Above 25mm models include one setting standard bar
- All models include warranty card, manual, and JCC calibration certificate

■ **Micrometer Set (Standard)**
Graduation : 0.01mm



OM-9001

Model No.	Measuring Range	Accuracy
OM-9001	0-25mm	4um
OM-9002	25-50mm	4um
OM-9003	50-75mm	5um
OM-9004	75-100mm	5um
OM-9005	100-125mm	6um
OM-9006	125-150mm	6um
OM-9007	150-175mm	7um
OM-9008	175-200mm	7um
OM-9009	200-225mm	8um
OM-9010	225-250mm	8um
OM-9011	250-275mm	9um
OM-9012	275-300mm	9um

Model No.	Measuring Range	Remark
OM-9013	0-75mm	3pcs/set
OM-9014	0-100mm	4pcs/set
OM-9015	0-150mm	6pcs/set
OM-9016	150-300mm	6pcs/set
OM-9017	0-300mm	12pcs/set



OM-9005



OM-9014



OM-9015

■ Outside Micrometer (Micron)

Graduation : 0.001mm



Heat insulating plastic frame cover



Cast steel Lightweight & Convenient

Model No.	Measuring Range	Accuracy
OM-9018H	0-25mm	4um
OM-9019H	25-50mm	4um
OM-9020H	50-75mm	5um
OM-9021H	75-100mm	5um

Model No.	Measuring Range	Accuracy
OM-9022H	0-25mm	4um
OM-9023H	25-50mm	4um
OM-9024H	50-75mm	5um
OM-9025H	75-100mm	5um

■ Outside Micrometer (100 Step Graduation)

Graduation : 0.01mm



1mm per revolution

- Φ 30mm diameter thimble with 100 step graduation for convenience and accuracy
- Each rotation is 1mm, None 0.5 mm vision error reading
- Φ 8mm measuring spindle and tungsten carbide anvil

Model No.	Measuring Range	Accuracy
OM-9026	0-25mm	4um
OM-9027	25-50mm	4um
OM-9028	50-75mm	5um
OM-9029	75-100mm	5um

■ **Outside Micrometer (Micro Parallax Free)**

Coplanar thimble laser engraved graduation sleeve, no visual error reading design.



Model No.	Measuring Range	Accuracy
OM-9034H	0-25mm	3um
OM-9035H	25-50mm	3um
OM-9036H	50-75mm	4um
OM-9037H	75-100mm	4um
OM-9038H	100-125mm	5um
OM-9039H	125-150mm	5um
OM-9040H	150-175mm	6um
OM-9041H	175-200mm	6um

Graduation : 0.001mm

■ **Outside Micrometer (Mechanical Digits)**

Digital design of mechanical stopwatch, easy to read, fast and accurate.



Model No.	Measuring Range	Accuracy
OM-9042	0-25mm	4um
OM-9043	25-50mm	4um
OM-9044	50-75mm	5um
OM-9045	75-100mm	5um
OM-9046	100-125mm	6um
OM-9047	125-150mm	6um
OM-9048	150-175mm	7um
OM-9049	175-200mm	7um
OM-9050	200-225mm	8um
OM-9051	225-250mm	8um
OM-9052	250-275mm	9um
OM-9053	275-300mm	9um

Graduation : 0.01mm

■ Outside Micrometer (Interchangeable Anvil)

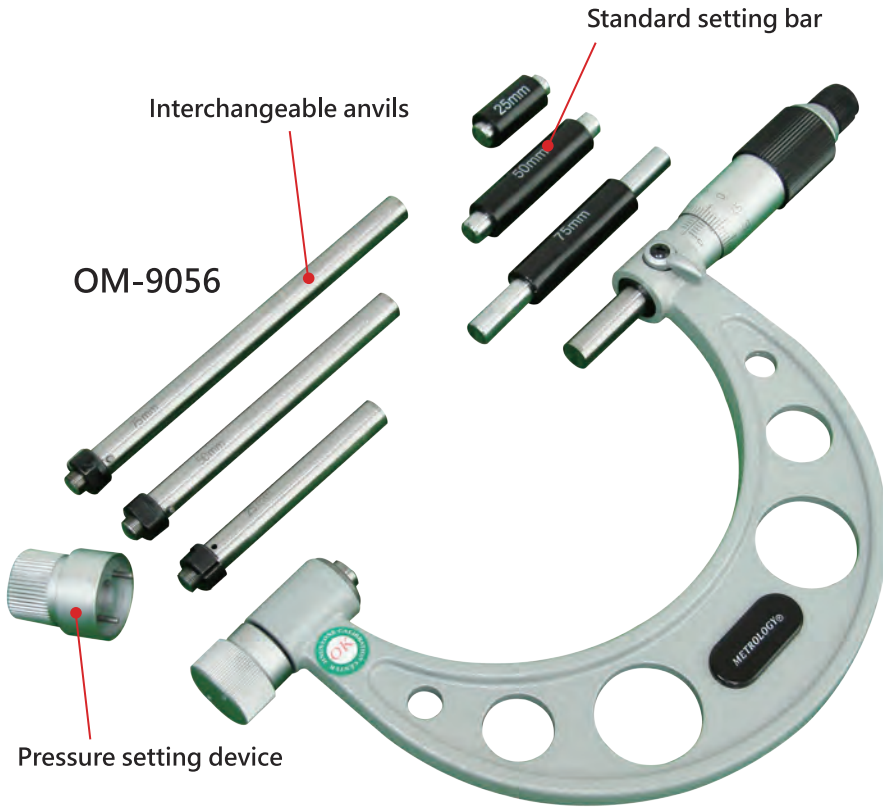

Model No.	Measuring Range	Accuracy
OM-9054	0-150mm	5um
OM-9055	150-300mm	8um
OM-9056	0-100mm	4um
OM-9057	100-200mm	6um
OM-9058	200-300mm	8um
OM-9059	300-400mm	10um
OM-9060	400-500mm	12um
OM-9061	500-600mm	13um
OM-9062	600-700mm	14um
OM-9063	700-800mm	16um
OM-9064	800-900mm	18um
OM-9065	900-1000mm	19um
OM-9066	1000-1200mm	20um
OM-9067	1200-1400mm	22um
OM-9068	1400-1600mm	24um
OM-9069	1600-1800mm	27um
OM-9070	1800-2000mm	30um

Graduation : 0.01mm

- Measuring range 300mm or under come with painted cast iron frames

■ Digital



Model No.	Measuring Range	Accuracy
EM-9054	0-150mm	±5um
EM-9055	150-300mm	±7um
EM-9056	0-100mm	±4um
EM-9057	100-200mm	±6um
EM-9058	200-300mm	±7um
EM-9059	300-400mm	±8um
EM-9060	400-500mm	±9um
EM-9061	500-600mm	±10um
EM-9062	600-700mm	±11um
EM-9063	700-800mm	±13um
EM-9064	800-900mm	±15um
EM-9065	900-1000mm	±17um

Resolution : 0.001mm/ 0.00005"
IP54 water/dust protection

■ Outside Micrometer (Interchangeable Anvil)



- Measuring range 300mm or over come with painted steel tube frame with insulating grips



■ Outside Micrometer (Small Face)

For measuring grooves, feather grooves, splines and other difficult to reach measuring points.



Model No.	Measuring Range	Accuracy
OM-9071	0-25mm	4um
OM-9072	25-50mm	4um
OM-9073	50-75mm	5um
OM-9074	75-100mm	5um
OM-9075	100-125mm	6um
OM-9076	125-150mm	6um
OM-9077	150-175mm	7um
Tungsten steel measuring tip $\phi 2 * L5mm$		
OM-9078	0-25mm	4um
OM-9079	25-50mm	4um
OM-9080	50-75mm	5um
OM-9081	75-100mm	5um
OM-9082	100-125mm	6um
OM-9083	125-150mm	6um
OM-9084	150-175mm	7um
Tungsten steel measuring tip $\phi 3 * L10mm$		

Graduation : 0.01mm

■ Digital



Model No.	Measuring Range	Accuracy
EM-9071	0-25mm	$\pm 3um$
EM-9072	25-50mm	$\pm 3um$
EM-9073	50-75mm	$\pm 4um$
EM-9074	75-100mm	$\pm 4um$
EM-9075	100-125mm	$\pm 5um$
EM-9076	125-150mm	$\pm 5um$
EM-9077	150-175mm	$\pm 6um$
Tungsten steel measuring tip $\phi 2 * L5mm$		
EM-9078	0-25mm	$\pm 3um$
EM-9079	25-50mm	$\pm 3um$
EM-9080	50-75mm	$\pm 4um$
EM-9081	75-100mm	$\pm 4um$
EM-9082	100-125mm	$\pm 5um$
EM-9083	125-150mm	$\pm 5um$
EM-9084	150-175mm	$\pm 6um$
Tungsten steel measuring tip $\phi 3 * L10mm$		

Resolution: 0.001mm/ 0.00005"
IP 54 water/dust protection

■ Outside Micrometer (Point)

For measuring the web thickness of drills, tap, small grooves, and other hard-to-reach places.



OM-9085

Model No.	Measuring Range	Accuracy
OM-9085	0-25mm	4um
OM-9086	25-50mm	4um
OM-9087	50-75mm	5um
OM-9088	75-100mm	5um
Tungsten steel		Tip angle 30°/ R.0.3mm
OM-9089	0-25mm	4um
OM-9090	25-50mm	4um
OM-9091	50-75mm	5um
OM-9092	75-100mm	5um
Tungsten steel		Tip angle 15°/ R.0.3mm

Graduation : 0.01mm

■ Digital



EM-9089

Model No.	Measuring Range	Accuracy
EM-9085	0-25mm	±3um
EM-9086	25-50mm	±3um
EM-9087	50-75mm	±4um
EM-9088	75-100mm	±4um
Tungsten steel		Tip angle 30°/ R.0.3mm
EM-9089	0-25mm	±3um
EM-9090	25-50mm	±3um
EM-9091	50-75mm	±4um
EM-9092	75-100mm	±4um
Tungsten steel		Tip angle 15°/ R.0.3mm

Resolution: 0.001mm/ 0.00005"
IP 54 water/dust protection

■ Outside Micrometer (Disk)

Designed to easily measure root tangent length of spur gears and herical gears.



Model No.	Measuring Range	Accuracy
OM-9093	0-25mm	4um
OM-9094	25-50mm	4um
OM-9095	50-75mm	5um
OM-9096	75-100mm	5um
Steel disc ϕ 20mm (Non-rotating Spindle)		
OM-9097	100-125mm	6um
OM-9098	125-150mm	6um
OM-9099	150-175mm	7um
OM-9100	175-200mm	7um
Steel disc ϕ 30mm (Non-rotating Spindle)		

Graduation : 0.01mm

■ Digital



Model No.	Measuring Range	Accuracy
EM-9093	0-25mm	$\pm 3\mu\text{m}$
EM-9094	25-50mm	$\pm 3\mu\text{m}$
EM-9095	50-75mm	$\pm 4\mu\text{m}$
EM-9096	75-100mm	$\pm 4\mu\text{m}$
Steel disc ϕ 20mm (Non-rotating Spindle)		
EM-9097	100-125mm	$\pm 5\mu\text{m}$
EM-9098	125-150mm	$\pm 5\mu\text{m}$
EM-9099	150-175mm	$\pm 6\mu\text{m}$
EM-9100	175-200mm	$\pm 6\mu\text{m}$
Steel disc ϕ 30mm (Non-rotating Spindle)		

Resolution: 0.001mm/ 0.00005"
IP 54 water/dust protection

■ Outside Micrometer (Jaw)

For measuring outside edge shoulders dimensions of workpiece.

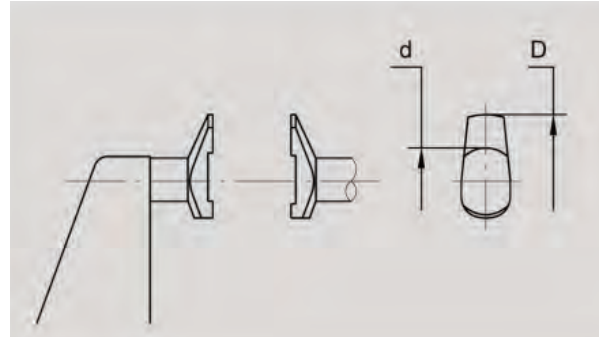

Graduation : 0.01mm

Model No.	Measuring Range	Accuracy	D	d
OM-9101	0-25mm	4um	R10	Φ8
OM-9102	25-50mm	4um	R10	Φ8
OM-9103	50-75mm	5um	R10	Φ8
OM-9104	75-100mm	5um	R10	Φ8
OM-9105	100-125mm	6um	R15	Φ12
OM-9106	125-150mm	6um	R15	Φ12
OM-9107	150-175mm	7um	R15	Φ12
OM-9108	175-200mm	7um	R15	Φ12

Tungsten carbide measuring anvil/non-rotating spindle

■ Digital



Resolution: 0.001mm/ 0.00005"
IP 54 water/dust protection

Model No.	Measuring Range	Accuracy	D	d
EM-9101	0-25mm	±3um	R10	Φ8
EM-9102	25-50mm	±3um	R10	Φ8
EM-9103	50-75mm	±4um	R10	Φ8
EM-9104	75-100mm	±4um	R10	Φ8
EM-9105	100-125mm	±5um	R15	Φ12
EM-9106	125-150mm	±5um	R15	Φ12
EM-9107	150-175mm	±6um	R15	Φ12
EM-9108	175-200mm	±6um	R15	Φ12

Tungsten carbide measuring anvil/non-rotating spindle

■ Outside Micrometer (Blade)

For measuring the groove diameter of shafts, keyways, and other hard-to-reach portions.



OM-9109

Model No.	Measuring Range	Accuracy
OM-9109	0-25mm	4um
OM-9110	25-50mm	4um
OM-9111	50-75mm	5um
OM-9112	75-100mm	5um
OM-9113	100-125mm	6um
OM-9114	125-150mm	6um
OM-9115	150-175mm	7um
Hardened steel T0.75*L6.5mm(Non-rotating Spindle)		
OM-9109S	0-25mm	4um
OM-9110S	25-50mm	4um
OM-9111S	50-75mm	5um
OM-9112S	75-100mm	5um
OM-9113S	100-125mm	6um
OM-9114S	125-150mm	6um
OM-9115S	150-175mm	7um
Hardened steel T0.4*L3.5mm (Non-rotating Spindle)		

Graduation : 0.01mm

■ Digital



EM-9019S

Model No.	Measuring Range	Accuracy
EM-9109	0-25mm	±3um
EM-9110	25-50mm	±3um
EM-9111	50-75mm	±4um
EM-9112	75-100mm	±4um
EM-9113	100-125mm	±5um
EM-9114	125-150mm	±5um
EM-9115	150-175mm	±6um
Hardened steel T0.75*L6.5mm (Non-rotating Spindle)		
EM-9109S	0-25mm	±3um
EM-9110S	25-50mm	±3um
EM-9111S	50-75mm	±4um
EM-9112S	75-100mm	±4um
EM-9113S	100-125mm	±5um
EM-9114S	125-150mm	±5um
EM-9115S	150-175mm	±6um
Hardened steel T0.4*L3.5mm (Non-rotating Spindle)		

Resolution: 0.001mm/ 0.00005"
IP 54 water/dust protection

■ Outside Micrometer (Universal)

For measuring outside dimension and diameter of varies shapes of workpieces.



Graduation : 0.01mm

Model No.	Measuring Range	Accuracy
OM-9116	0-25mm	4um
OM-9117	25-50mm	4um
OM-9118	50-75mm	5um
OM-9119	75-100mm	5um
OM-9120	100-125mm	6um
OM-9121	125-150mm	6um
OM-9122	150-175mm	7um
OM-9123	175-200mm	7um

Include set AV-9008 with 7 pairs interchangeable measuring anvils, non-rotating spindle.

■ Digital (Universal)

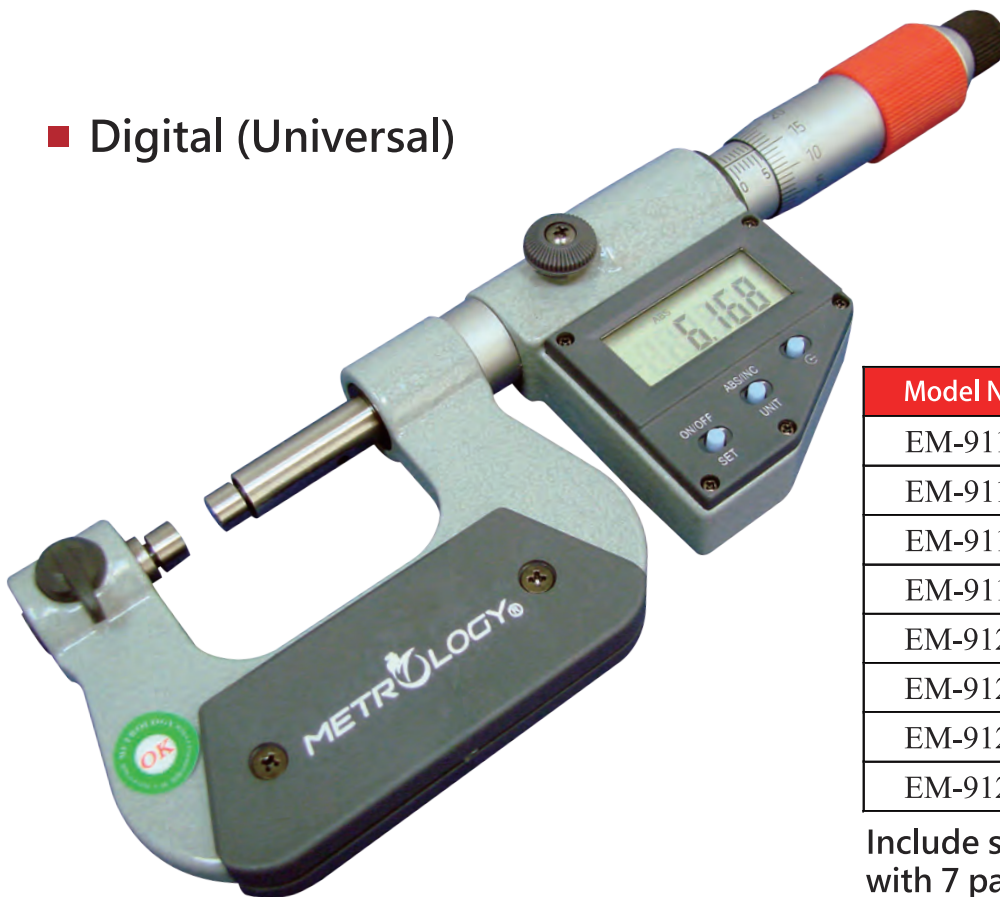

Resolution: 0.001mm/ 0.00005"
IP 54 water/dust protection







Model No.	Measuring Range	Accuracy
EM-9116	0-25mm	±3um
EM-9117	25-50mm	±3um
EM-9118	50-75mm	±4um
EM-9119	75-100mm	±4um
EM-9120	100-125mm	±5um
EM-9121	125-150mm	±5um
EM-9122	150-175mm	±6um
EM-9123	175-200mm	±6um

Include set AV-9008 with 7 pairs interchangeable measuring anvils, non-rotating spindle.



■ Outside Micrometer (Universal)

Interchangeable Anvils

Model No.	Anvil	Remark
AV-9001	Flat	
AV-9002	Spherical	
AV-9003	Blade	
AV-9004	Point	
AV-9005	Spine	
AV-9006	Disk	
AV-9007	Knife-edge	
AV-9008	7 pairs/Set	Anvil dia.5mm, length 4.5mm Overall length 15mm

Remark: Anvils can be purchased individually.

■ Outside Micrometer (Tube)

For measuring the tube wall thickness and other curved workpieces.



OM-9128

Model No.	Measuring Range	Accuracy	Anvil
OM-9124	0-25mm	4um	A
OM-9125	25-50mm	4um	A
OM-9126	0-25mm	4um	B
OM-9127	25-50mm	4um	B
OM-9128	0-25mm	4um	C
OM-9129	25-50mm	4um	C
OM-9130	0-25mm	4um	D
OM-9131	25-50mm	4um	D
OM-9132	0-25mm	4um	E
OM-9133	25-50mm	4um	E
OM-9134	0-25mm	4um	F
OM-9135	25-50mm	4um	F
OM-9136	0-25mm	4um	J
OM-9137	25-50mm	4um	J
OM-9138	0-25mm	4um	K
OM-9139	25-50mm	4um	K
OM-9140	50-75mm	5um	K
OM-9141	75-100mm	5um	K

Graduation : 0.01mm

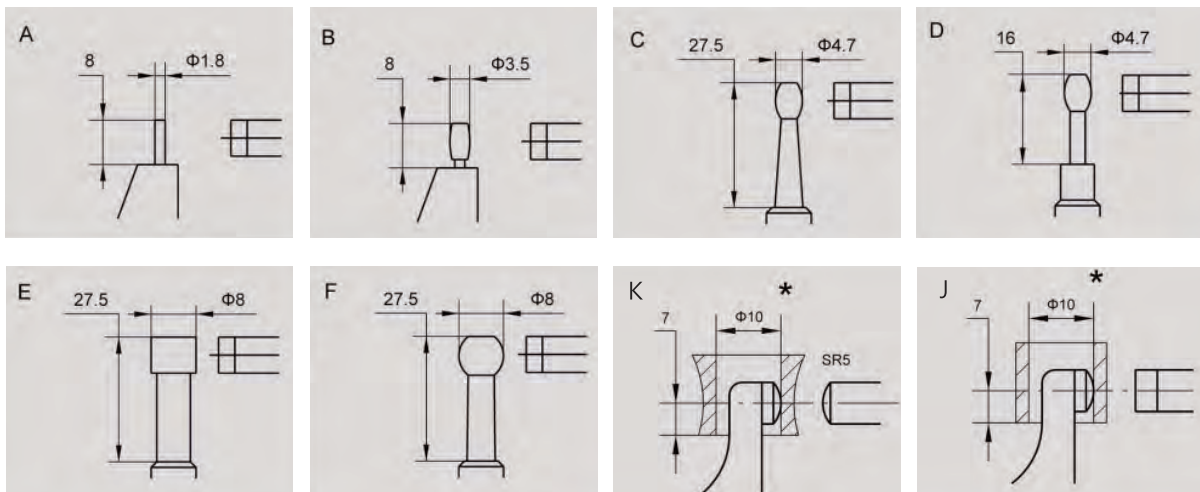

■ Outside Micrometer (Tube)

For measuring the tube wall thickness and other curved workpieces.



■ Digital

EM-9124

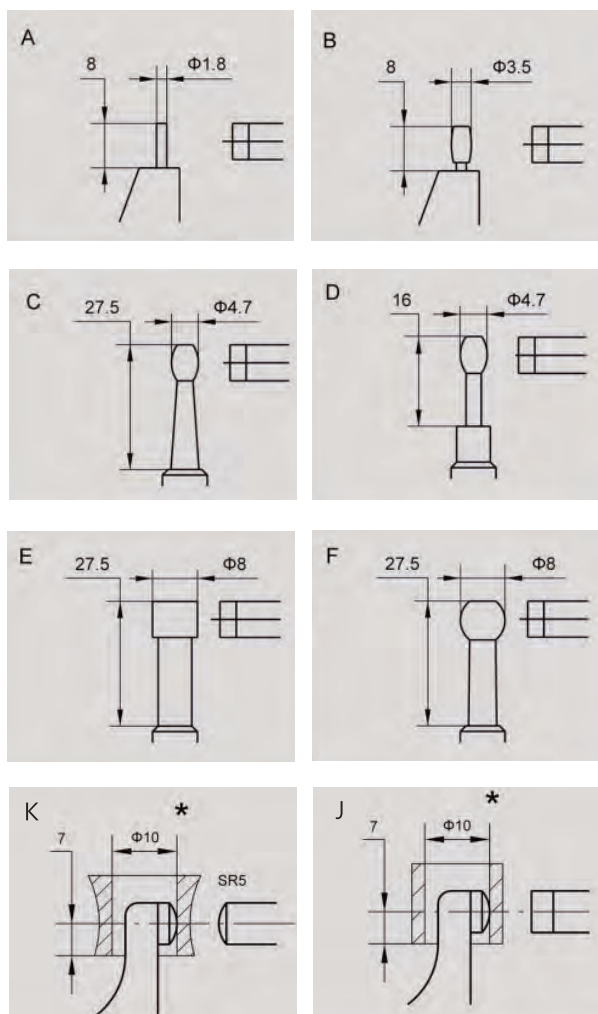

Model No.	Measuring Range	Accuracy	Anvil
EM-9124	0-25mm	±3um	A
EM-9125	25-50mm	±3um	A
EM-9126	0-25mm	±3um	B
EM-9127	25-50mm	±3um	B
EM-9128	0-25mm	±3um	C
EM-9129	25-50mm	±3um	C
EM-9130	0-25mm	±3um	D
EM-9131	25-50mm	±3um	D
EM-9132	0-25mm	±3um	E
EM-9133	25-50mm	±3um	E
EM-9134	0-25mm	±3um	F
EM-9135	25-50mm	±3um	F
EM-9136	0-25mm	±3um	J
EM-9137	25-50mm	±3um	J
EM-9138	0-25mm	±3um	K
EM-9139	25-50mm	±3um	K
EM-9140	50-75mm	±4um	K
EM-9141	75-100mm	±4um	K

Resolution: 0.001mm/ 0.00005"
IP 54 water/dust protection

■ Outside Micrometer (V-Anvil)

For measuring test pieces with an uneven number of grooves such as milling cutters, taps, drills and spline shafts as well as odd polygons.



Model No.	Measuring Range	Accuracy	Remark
OM-9142	1-15mm	4um	Tungsten steel 3Flute 60°
OM-9143	5-20mm	4um	
OM-9144	20-35mm	4um	
OM-9145	35-50mm	4um	
OM-9146	50-65mm	5um	
OM-9147	65-80mm	5um	
OM-9148	80-95mm	5um	Tungsten steel 5Flute 108°
OM-9149	2.3-25mm	4um	
OM-9150	25-50mm	4um	
OM-9151	5-25mm	4um	
OM-9152	25-45mm	4um	
OM-9153	45-65mm	5um	
OM-9154	65-85mm	5um	Tungsten steel 7Flute 128°34'17"
OM-9155	85-105mm	5um	
OM-9156	5-25mm	4um	
OM-9157	25-45mm	4um	
OM-9158	45-65mm	5um	
OM-9159	65-85mm	5um	

Graduation : 0.01mm

■ Digital



Model No.	Measuring Range	Accuracy	Remark
EM-9142	1-15mm	±3um	Tungsten steel 3Flute 60°
EM-9143	5-20mm	±3um	
EM-9144	20-35mm	±3um	
EM-9145	35-50mm	±3um	
EM-9146	50-65mm	±4um	
EM-9147	65-80mm	±4um	
EM-9148	80-95mm	±4um	Tungsten steel 5Flute 108°
EM-9149	2.3-25mm	±3um	
EM-9150	25-50mm	±3um	
EM-9151	5-25mm	±3um	
EM-9152	25-45mm	±3um	
EM-9153	45-65mm	±4um	
EM-9154	65-85mm	±4um	Tungsten steel 7Flute 128°34'17"
EM-9155	85-105mm	±4um	
EM-9156	5-25mm	±3um	
EM-9157	25-45mm	±3um	
EM-9158	45-65mm	±4um	
EM-9159	65-85mm	±4um	

Resolution: 0.001mm/ 0.00005"
IP 54 water/dust protection

- **Outside Micrometer (Screw Thread)**
For measuring pitch diameter of screw thread.



Model No.	Measuring Range	Accuracy
OM-9160	0-25mm	4um
OM-9161	25-50mm	4um
OM-9162	50-75mm	5um
OM-9163	75-100mm	5um
OM-9164	100-125mm	6um
OM-9165	125-150mm	6um
OM-9166	150-175mm	7um
OM-9167	175-200mm	7um

non- rotating spindle
Graduation : 0.01mm

Optional interchangeable anvils (spe. see F26)

- **Digital**



Model No.	Measuring Range	Accuracy
EM-9160	0-25mm	±3um
EM-9161	25-50mm	±3um
EM-9162	50-75mm	±4um
EM-9163	75-100mm	±4um
EM-9164	100-125mm	±5um
EM-9165	125-150mm	±5um
EM-9166	150-175mm	±6um
EM-9167	175-200mm	±6um

Optional interchangeable anvils (spe. see F26)

non- rotating spindle
Resolution: 0.001mm/ 0.00005"
IP 54 water/dust protection

■ Outside Micrometer (Optional Screw Thread Anvil)



Model No.	Metric & Inch (60°)	Accuracy (Anvil)
AV-9009	0.4-0.5mm/64-48TPI	4um
AV-9010	0.6-0.9mm/44-28TPI	4um
AV-9011	1-1.75mm/24-14TPI	5um
AV-9012	2-3mm/13-9TPI	5um
AV-9013	3.5-5mm/8-5TPI	6um
AV-9014	5.5-7mm/4.5-3.5TPI	6um
AV-9015	0.4-7mm/64-3.5TPI (set)	

Measuring Range	Anvil Sets
0-25mm	AV9009-9013
25-50mm	AV9010-9014
50-75mm	AV9011-9014
75-100mm	AV9011-9014
100-200mm	AV9012-9014

Hardened steel
interchangeable anvil
(Optional)

Anvils can be purchased individually

Measuring Diagram

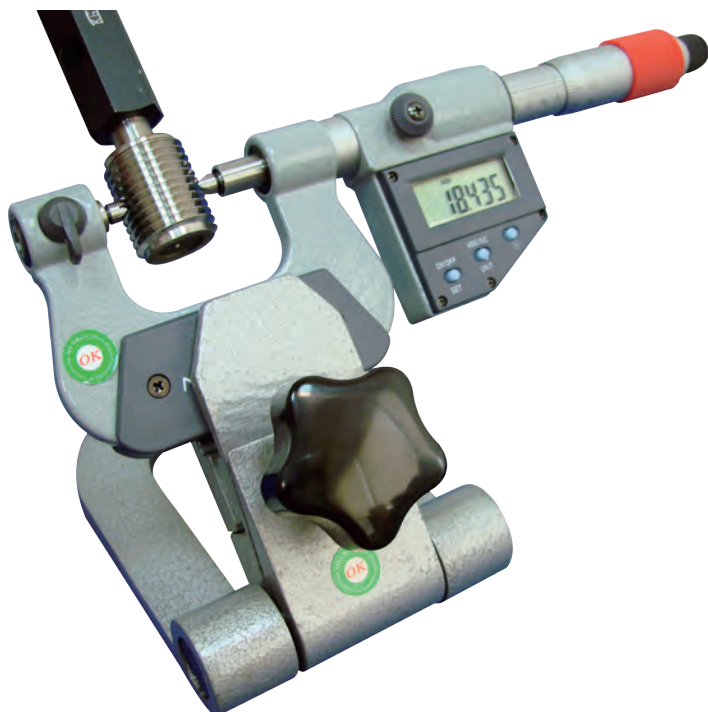
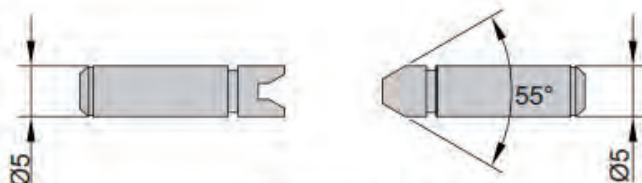
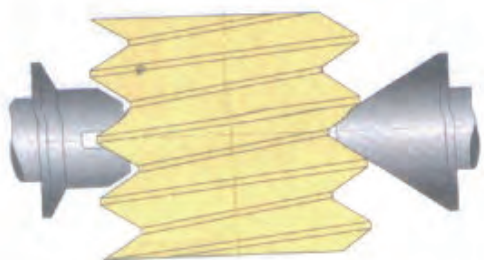

Model No.	Whitworth (55°)	Accuracy (Anvil)
AV-9016	60-48 TPI	4um
AV-9017	48-40 TPI	4um
AV-9018	40-32 TPI	5um
AV-9019	32-24 TPI	5um
AV-9020	24-18 TPI	5um
AV-9021	18-14 TPI	5um
AV-9022	14-10 TPI	5um
AV-9023	10-7 TPI	5um
AV-9024	7-4.5 TPI	6um
AV-9025	4.5-3.5 TPI	6um
AV-9026	60-3.5 TPI(set)	

Anvils can be purchased individually

■ Outside Micrometer (Gear Root Diameter)

For measuring root diameter of gears, small flutes, recesses, grooved wires, keyways and other hard-to-reach areas.



Model No.	Measuring Range	Accuracy	Anvil Radius
OM-9168	5-100mm	4um	R: 0.4mm
OM-9169	100-200mm	6um	R: 0.5mm
OM-9170	200-300mm	8um	R: 0.7mm
OM-9171	300-400mm	10um	
OM-9172	400-500mm	12um	
OM-9173	500-600mm	13um	
OM-9174	600-700mm	15um	
OM-9175	700-800mm	16um	
OM-9176	800-900mm	18um	

Graduation : 0.01mm
carbide measuring tips

■ Digital



Model No.	Measuring Range	Accuracy	Anvil Radius
EM-9168	5-100mm	±3um	R: 0.4mm
EM-9169	100-200mm	±4um	R: 0.5mm
EM-9170	200-300mm	±5um	R: 0.7mm
EM-9171	300-400mm	±5um	
EM-9172	400-500mm	±6um	
EM-9173	500-600mm	±6um	
EM-9174	600-700mm	±7um	
EM-9175	700-800mm	±7um	
EM-9176	800-900mm	±8um	

Resolution: 0.001mm/ 0.00005"
IP 54 water/dust protection
carbide measuring tips

■ Outside Micrometer (Deep Throat)

For measuring thickness of sheet metal, paper, plastic, and rubber parts.



Model No.	Measuring Range	Accuracy	Deep Throat
OM-9178A	0-25mm	4um	50mm
OM-9179A	25-50mm	5um	50mm
OM-9180A	0-25mm	4um	100mm
OM-9181A	25-50mm	5um	100mm
OM-9182A	0-25mm	4um	150mm
OM-9183A	25-50mm	5um	150mm
OM-9184A	0-25mm	4um	300mm
OM-9185A	25-50mm	5um	300mm
OM-9178B	0-25mm	4um	50mm
OM-9179B	25-50mm	5um	50mm
OM-9180B	0-25mm	4um	100mm
OM-9181B	25-50mm	5um	100mm
OM-9182B	0-25mm	4um	150mm
OM-9183B	25-50mm	5um	150mm
OM-9184B	0-25mm	4um	300mm
OM-9185B	25-50mm	5um	300mm
OM-9178C	0-25mm	4um	50mm
OM-9179C	25-50mm	5um	50mm
OM-9180C	0-25mm	4um	100mm
OM-9181C	25-50mm	5um	100mm
OM-9182C	0-25mm	4um	150mm
OM-9183C	25-50mm	5um	150mm
OM-9184C	0-25mm	4um	300mm
OM-9185C	25-50mm	5um	300mm

Graduation : 0.01mm
carbide measuring faces

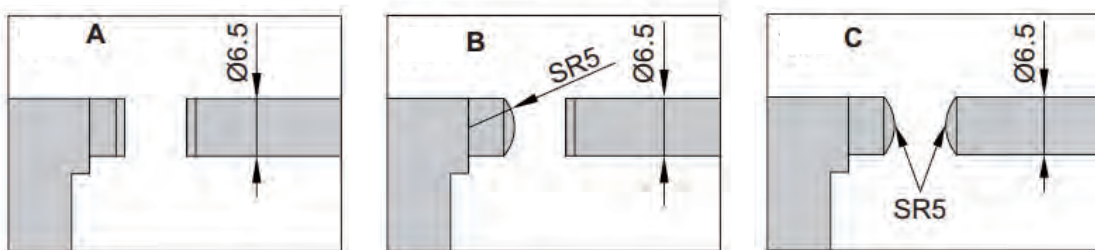

■ Outside Micrometer (Deep Throat)

For measuring thickness of sheet metal, paper, plastic, and rubber parts.

■ Digital



EM-9180A

型號	量測範圍(mm)	精度(um)	喉深(mm)
EM-9178A	0-25	±3	50
EM-9179A	25-50	±4	50
EM-9180A	0-25	±3	100
EM-9181A	25-50	±4	100
EM-9182A	0-25	±3	150
EM-9183A	25-50	±4	150
EM-9184A	0-25	±3	300
EM-9185A	25-50	±4	300
EM-9178B	0-25	±3	50
EM-9179B	25-50	±4	50
EM-9180B	0-25	±3	100
EM-9181B	25-50	±4	100
EM-9182B	0-25	±3	150
EM-9183B	25-50	±4	150
EM-9184B	0-25	±3	300
EM-9185B	25-50	±4	300
EM-9178C	0-25	±3	50
EM-9179C	25-50	±4	50
EM-9180C	0-25	±3	100
EM-9181C	25-50	±4	100
EM-9182C	0-25	±3	150
EM-9183C	25-50	±4	150
EM-9184C	0-25	±3	300
EM-9185C	25-50	±4	300

Resolution: 0.001mm/ 0.00005"

IP54 water/dust protection

carbide measuring faces

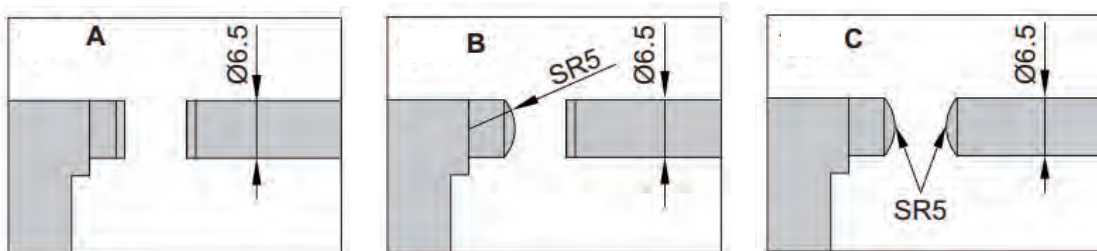

■ Outside Micrometer (Large Anvil)

For inspecting the width of milling cutters with staggered teeth.



Model No.	Measuring Range	Accuracy	Anvil
OM-9186	0-25mm	4um	L50*T14
OM-9187	25-50mm	4um	L60*T14

Graduation : 0.01mm

Hardened steel measuring big face,
measuring spindle with tungsten carbide face

■ Outside Micrometer (Outside Caliper)

For measuring outside edge shoulders dimensions of workpieces.



Model No.	Measuring Range	Accuracy
OM-9190	0-25mm	4um
OM-9191	25-50mm	4um
OM-9192	50-75mm	5um
OM-9193	75-100mm	5um

Graduation : 0.01mm

Radius tungsten carbide measuring anvil

■ Outside Micrometer (Multi-Use)

For measuring tube thickness, shoulder-edge distance, rivet head height, and etc.



Model No.	Measuring Range	Accuracy	Anvil (mm)
OM-9188	0-25mm	4um	Rod ϕ 3 Flat T 1.5
OM-9189	25-50mm	4um	Rod ϕ 5 Flat T 1.5

Graduation : 0.01mm
Interchangeable hardened steel anvil
Measuring spindle with carbide faces

■ Digital



Model No.	Measuring Range	Accuracy	Anvil (mm)
EM-9188	0-25mm	\pm 3um	Rod ϕ 3 Flat T 1.5
EM-9189	25-50mm	\pm 3um	Rod ϕ 5 Flat T 1.5

Resolution: 0.001mm/ 0.00005"
IP 54 water/dust protection

Interchangeable hardened steel anvil
Measuring spindle with carbide faces

■ Outside Micrometer (Gear)

For measuring over-pin diameter of gears



Model No.	Measuring Range	Accuracy
OM-9198	0-25mm	4um
OM-9199	25-50mm	4um
OM-9200	50-75mm	5um
OM-9201	75-100mm	5um
OM-9202	100-125mm	6um
OM-9203	125-150mm	6um
OM-9204	150-175mm	7um

Graduation : 0.01mm

■ Digital



Model No.	Measuring Range	Accuracy
EM-9198	0-25mm	±3um
EM-9199	25-50mm	±3um
EM-9200	50-75mm	±4um
EM-9201	75-100mm	±4um
EM-9202	100-125mm	±5um
EM-9203	125-150mm	±5um
EM-9204	150-175mm	±6um

Resolution: 0.001mm/ 0.00005"
IP 54 water/dust protection

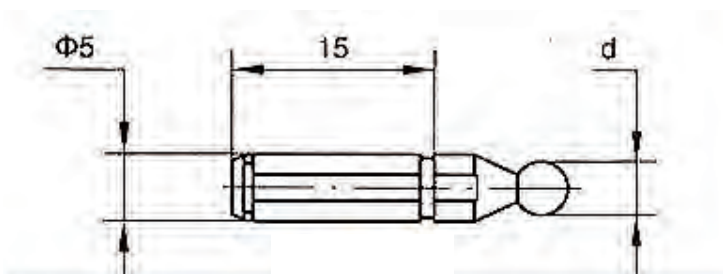

precision steel-ball-tipped(optional)

Model No.	Ball Diameter	Module/ Pitch Dia
AV-9027	Φ1.0mm	0.6-0.65 / 45
AV-9028	Φ1.5mm	0.9-1.0 / 28-26
AV-9029	Φ2.0mm	1.25 / 22
AV-9030	Φ2.5mm	1.5 / 17
AV-9031	Φ3.0mm	1.75 / 15
AV-9032	Φ3.5mm	2 / 13
AV-9033	Φ4.0mm	2.25 / 11
AV-9034	Φ4.5mm	2.5 / 10
AV-9035	Φ5.0mm	2.75 / 9
AV-9036	Φ6.0mm	3.5 / 7
AV-9037	Set	

Purchase separately

■ Outside Micrometer (Disc Brake)

For measuring thickness of disc brakes and irregular plates.



Model No.	Measuring Range	Accuracy
OM-9205	7.6-33mm	4um
OM-9206	25-50mm	4um
Tungsten steel Deep Throat: 88mm Tip angle: 30°		

Graduation : 0.01mm

■ Digital

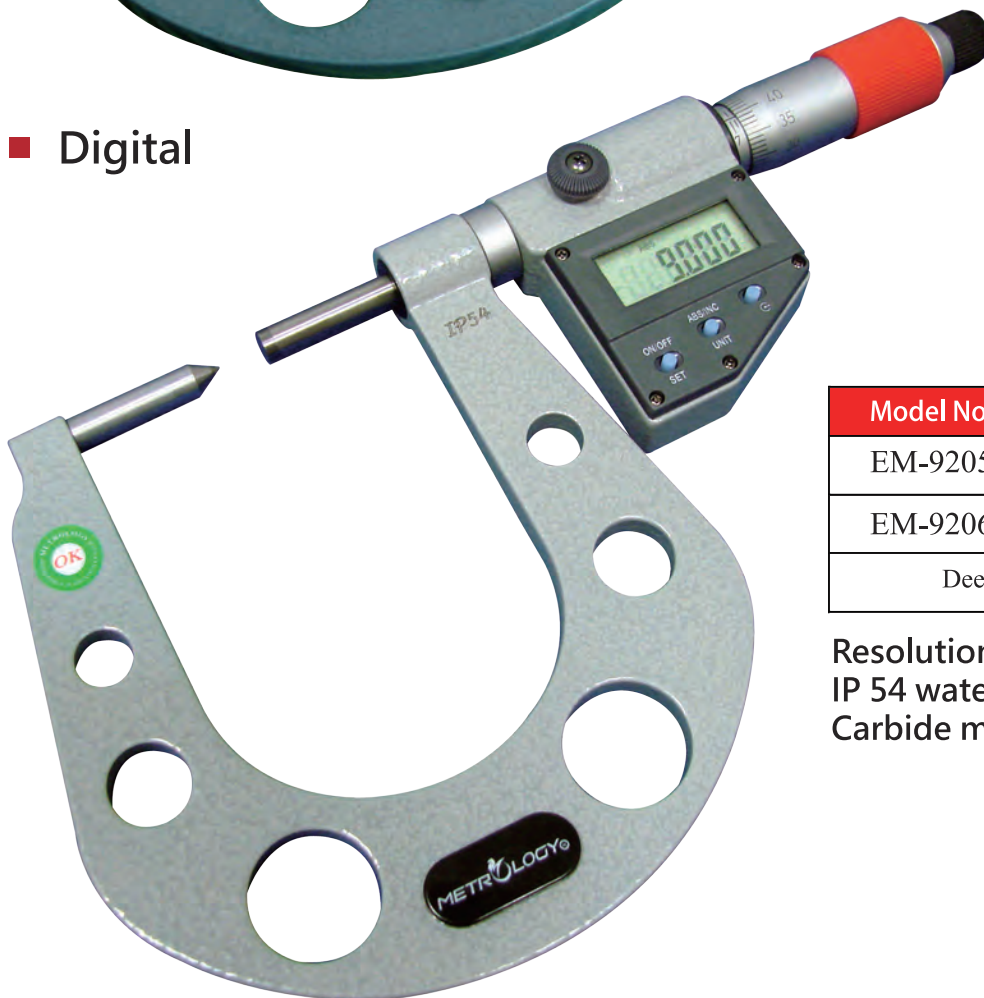

Model No.	Measuring Range	Accuracy
EM-9205	7.6-33mm	±4um
EM-9206	25-50mm	±4um
Deep Throat: 88mm Tip angle: 30°		

Resolution: 0.001mm/ 0.00005"
 IP 54 water/dust protection
 Carbide measuring faces

■ Outside Micrometer (Single Point)

For measuring the height of crimp contacts, thickness of drills, groove, and various hard to reach part.



Model No.	Measuring Range	Accuracy
OM-9207B	0-25mm	4um
OM-9208B	25-50mm	4um
OM-9209B	50-75mm	5um
OM-9210B	75-100mm	5um
OM-9207C	0-25mm	4um
OM-9207E	0-25mm	4um

Graduation : 0.01mm
Carbide measuring faces

■ Digital



Model No.	Measuring Range	Accuracy
EM-9207B	0-25mm	±3um
EM-9208B	25-50mm	±3um
EM-9209B	50-75mm	±4um
EM-9210B	75-100mm	±4um
EM-9207C	0-25mm	±3um
EM-9207E	0-25mm	±3um

Resolution: 0.001mm/ 0.00005"
IP 54 water/dust protection
Carbide measuring faces

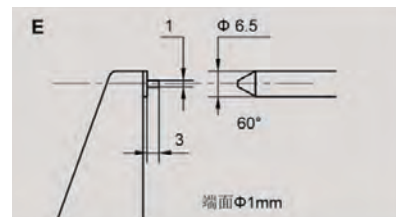
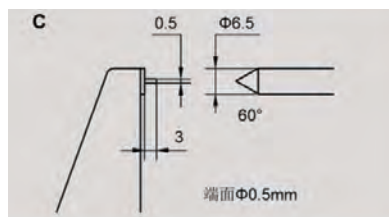
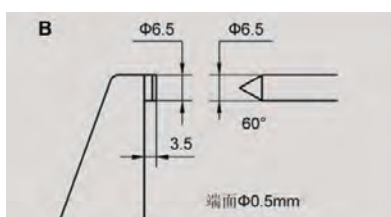

■ Outside Micrometer (Hub)

For measuring hub thickness, shoulders inside a bore, and outside diameter of cylindrical workpieces.

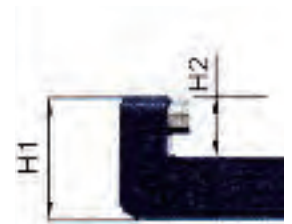
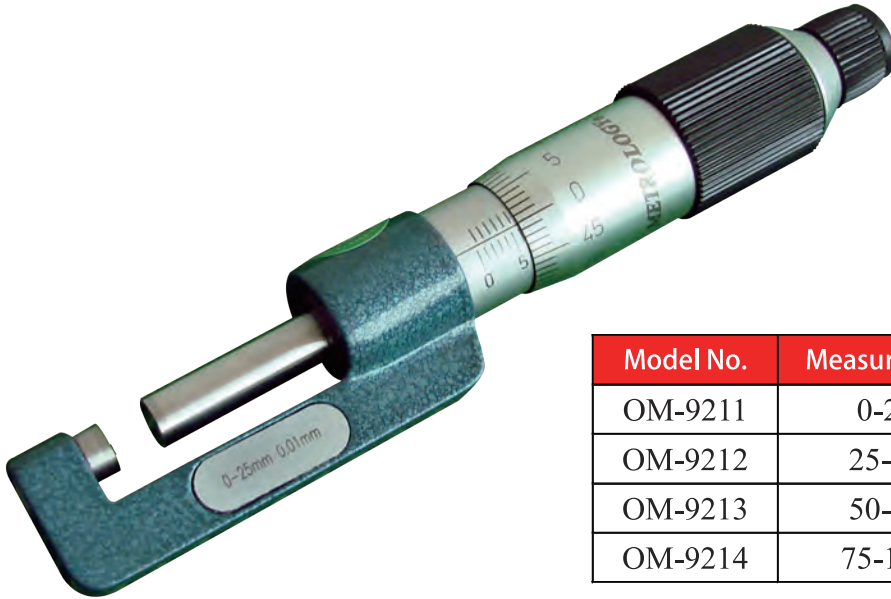

Model No.	Measuring Range	Accuracy	H1(mm)	H2(mm)
OM-9211	0-25mm	4um	18.7	10.2
OM-9212	25-50mm	4um	21.2	
OM-9213	50-75mm	5um	21.2	
OM-9214	75-100mm	5um	21.2	

Graduation : 0.01mm

■ Outside Micrometer (Mini)

For measuring small dimensions.



Φ20mm



Model No.	Measuring Range	Accuracy
OM-9215	0-15mm	4um

Graduation : 0.01mm

■ Outside Micrometer (Limit)

Dual set of measuring spindles and anvils for GO/NG inspection within tolerance limits.



Model No.	Measuring Range	Accuracy
OM-9216	0-25mm	4um
OM-9217	25-50mm	4um

Graduation: 0.002mm
Carbide measuring faces

■ Outside Micrometer (Can Seam)

For measuring the width, height, and depth of can seams.



OM-9222

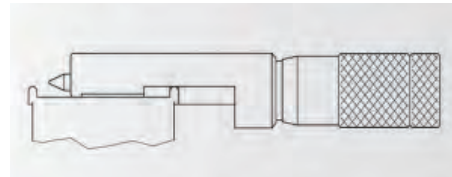

OM-9223

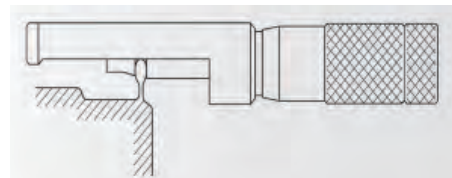

OM-9224

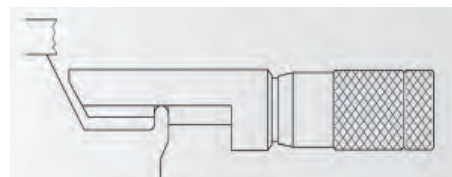

Graduation : 0.01mm

Model No.	Measuring Range	Accuracy	Remark
OM-9222	0-13mm	4um	Steel Can
OM-9223		4um	Aluminum Can
OM-9224		4um	Sprayer Can

■ Outside Micrometer (Wire)

For measuring diameter of wires, spherical diameter, and outside dimension of small cylindrical parts.



Model No.	Measuring Range	Accuracy
OM-9225	0-10mm	4um

Graduation: 0.01mm
Carbide measuring faces

■ Outside Micrometer (Large Disc)



Model No.	Measuring Range	Accuracy
OM-9226	0-25mm	4um
OM-9227	25-50mm	4um
OM-9228	50-75mm	5um
OM-9229	75-100mm	5um
Hardened steel ϕ 60mm (Non-rotating Spindle)		

Graduation : 0.01mm

■ Outside Micrometer (Groove)

For measuring width, depth, and location of grooves inside/outside bores, and tubes. Hardened steel measuring disc anvil with non-rotating spindle and two directional ratchet stop.



OM-9230

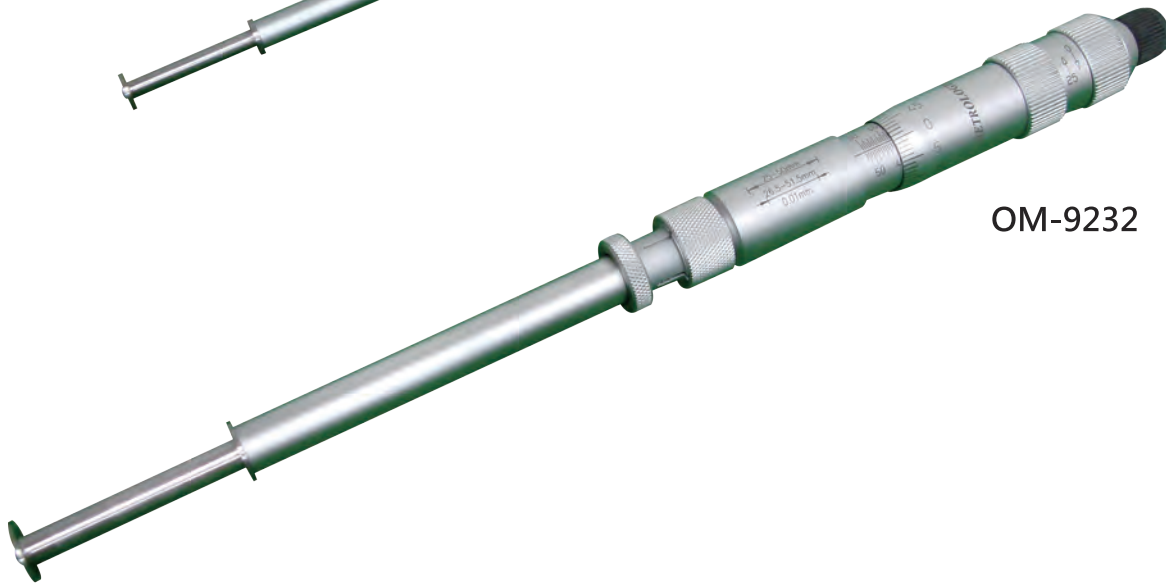

OM-9232

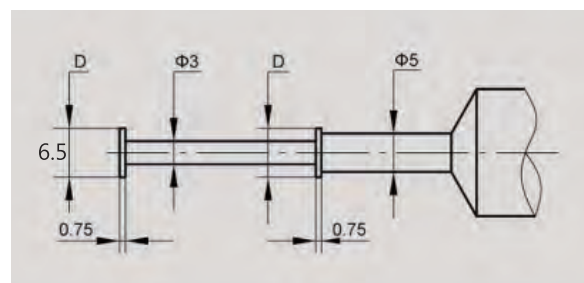
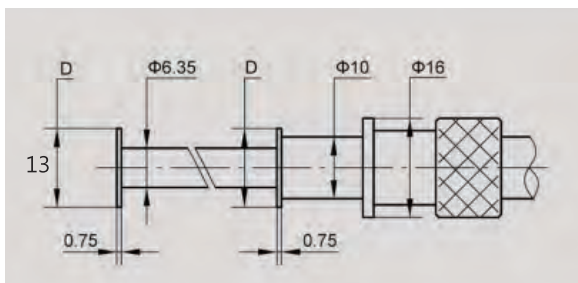

Model No.	Outside	Inside	Accuracy	Disc Diameter
OM-9230	0-25mm	1.6-26.5mm	5um	D: ϕ 6.5mm
OM-9231	0-25mm	1.6-26.5mm	5um	D: ϕ 13mm
OM-9232	25-50mm	26.5-51.5mm	6um	
OM-9233	50-75mm	51.5-76.5mm	6um	
OM-9234	75-100mm	76.5-101.5mm	7um	

Graduation : 0.01mm

■ Outside Micrometer (Micro Rapid Indicator)

For high precision & quick inspection of mass produced parts.



Model No.	Measuring Range	Accuracy
OM-9235	0-25mm	2um
OM-9236	25-50mm	2um
OM-9237	50-75mm	3um
OM-9238	75-100mm	3um



MS-9000H (optional)

■ Outside Dial Snap Comparator (Standard)

For quick inspection of mass-produced parts.

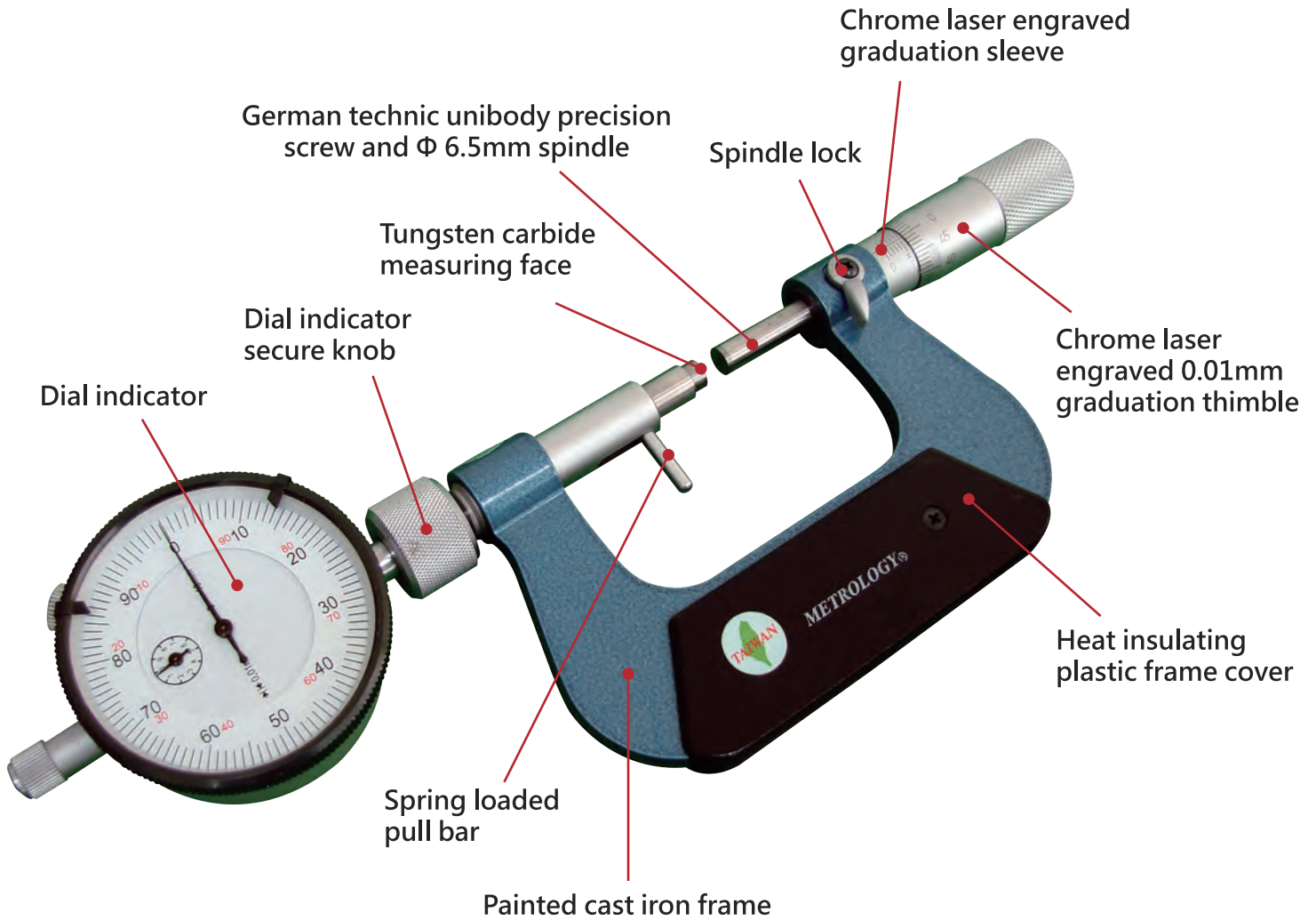

Model No.	Measuring Range	Accuracy
OM-SC01N	0-25mm	4um
OM-SC02N	25-50mm	4um
OM-SC03N	50-75mm	5um
OM-SC04N	75-100mm	5um
OM-SC05N	100-125mm	6um
OM-SC06N	125-150mm	6um
OM-SC07N	150-175mm	7um

0.01mm dial indicator included



MS-9000N (optional)

■ Outside Digital Snap Comparator (Long Travel)

For high precision & quick inspection of mass produced parts.

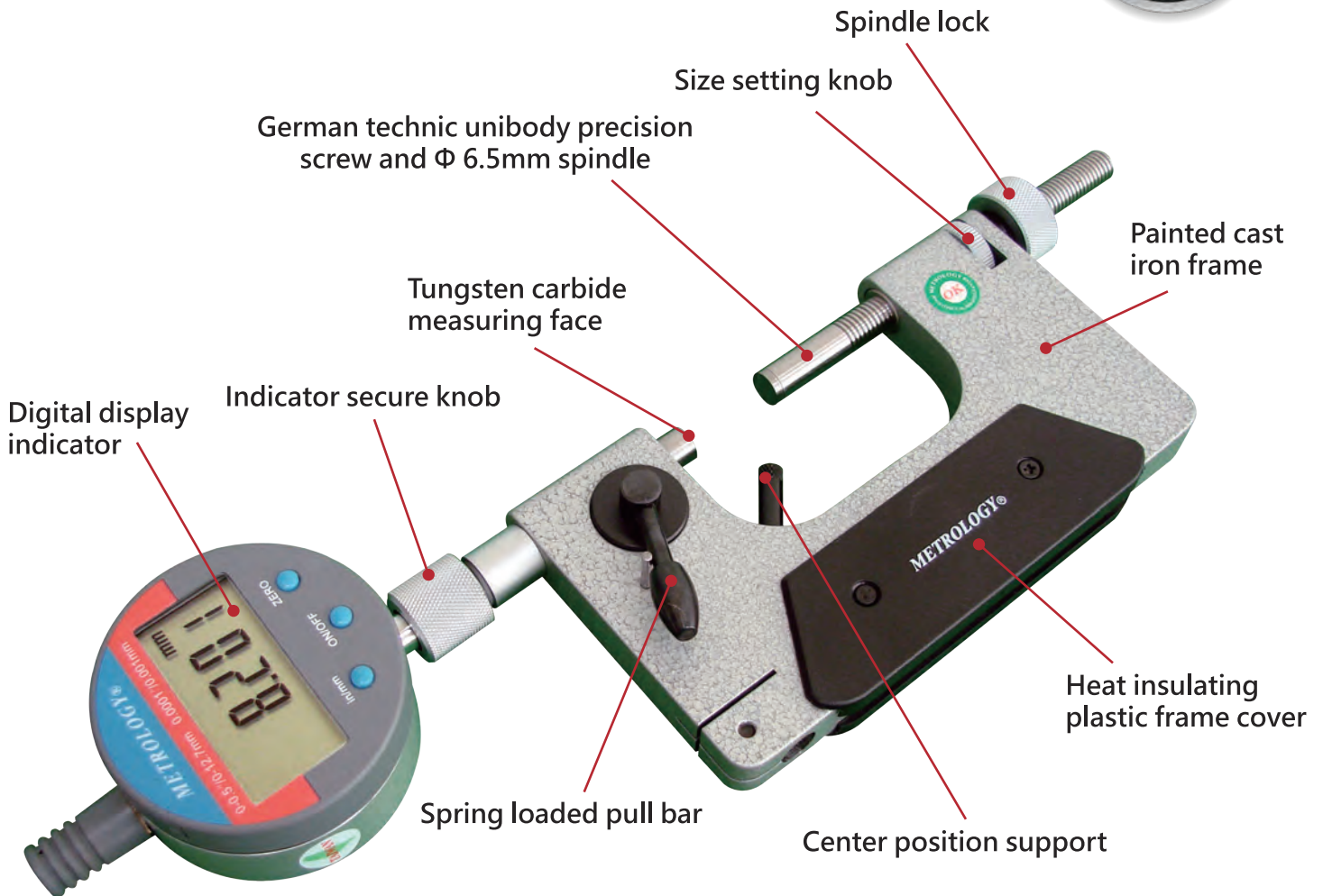

MS-9000H (optional)

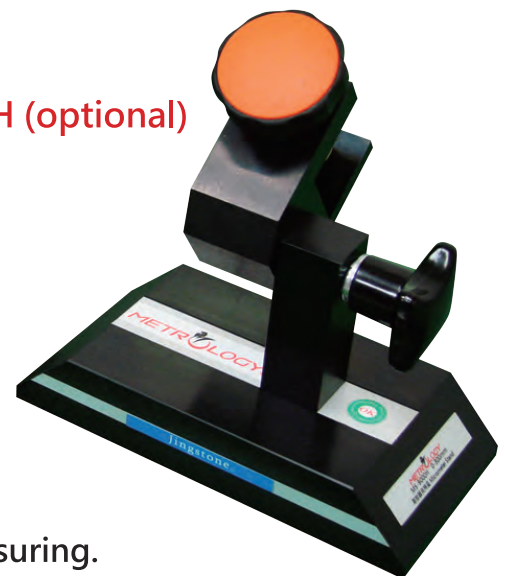

Model No.	Measuring Range	Accuracy
OM-SC00L	0-50mm	2um
OM-SC50L	50-100mm	2um
OM-SC100L	100-150mm	3um
OM-SC150L	150-200mm	3um

Indicator sold separately (optional purchase)

*It needs to be used with standard gauges block to measuring.

■ Outside Snap Comparator (Universal)

For quick inspection on varies shapes of mass-produced parts.

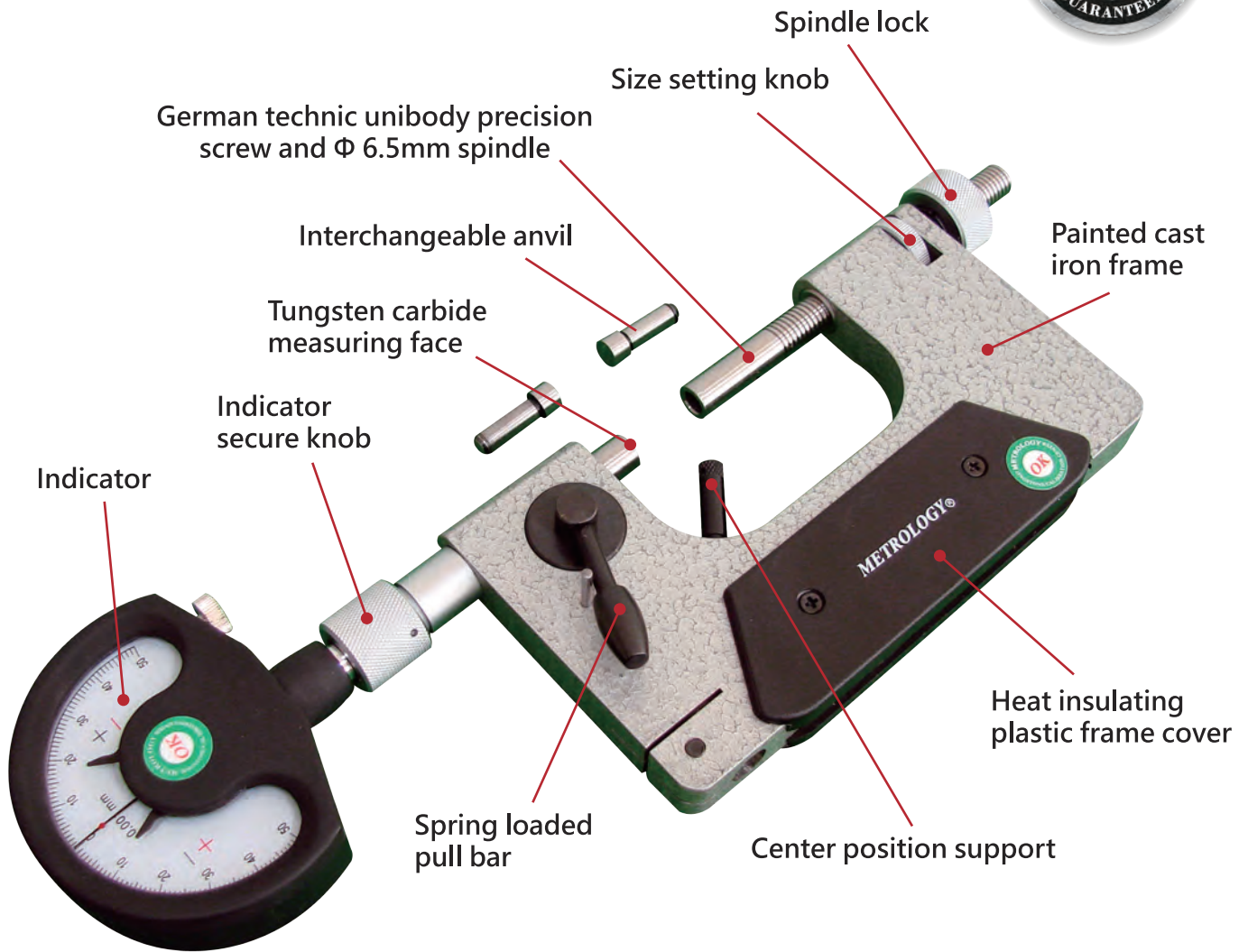

Interchangeable anvil (optional)

Model No.	Measuring Range	Accuracy
OM-SC00U	0-40mm	3um
OM-SC40U	40-90mm	3um
OM-SC90U	90-140mm	4um
OM-SC140U	140-190mm	4um

Anvil Style	Model No.
Universal	AV-9001 ~ 9008
60°Metric & Inch	AV-9009 ~ 9015
55°Whitworth	AV-9016 ~ AV-9026
Ball (Gear)	AV-9027 ~ AV-9037

Indicator sold separately (optional purchase)

*It needs to be used with standard gauges block to measuring.

■ **Micrometer Stands**

Suitable for holding outside micrometer for measurement.

Model No.	Measuring Range	Clamp Thickness	Material & Type
MS-9000S	0-50	15	Cast Iron (Simple)
MS-9000N	0-100	18	Cast Iron (Normal)
MS-9000H	0-300	25	Hardened Steel (Heavy)



MS-9000S



MS-9000N



MS-9000H



■ Depth Micrometer (Vernier)

For measuring depth, height, thickness, and steps.



DM-9002

Model No.	Measuring Range	Accuracy
DM-9001	0-25mm	4um
DM-9002	0-50mm	4um
DM-9003	0-100mm	5um
DM-9004	0-150mm	6um
DM-9005	0-200mm	7um
DM-9006	0-300mm	9um
Measuring Rod ϕ 4.5mm Base Length: 63mm		
DM-9007	0-25mm	4um
DM-9008	0-50mm	4um
DM-9009	0-100mm	5um
DM-90010	0-150mm	6um
DM-90011	0-200mm	7um
DM-90012	0-300mm	9um
Measuring Rod ϕ 4.5mm Base Length: 101.5mm		

Graduation : 0.01mm

Interchangeable hardened steel anvil

■ Depth Micrometer (Mechanical Digits)

For measuring depth, height, thickness, and steps.



DM-9009D

Model No.	Measuring Range	Accuracy
DM-9001D	0-25mm	4um
DM-9002D	0-50mm	4um
DM-9003D	0-100mm	5um
DM-9004D	0-150mm	6um
DM-9005D	0-200mm	7um
DM-9006D	0-300mm	9um
Measuring Rod ϕ 4.5mm Base Length: 63mm		
DM-9007D	0-25mm	4um
DM-9008D	0-50mm	4um
DM-9009D	0-100mm	5um
DM-90010D	0-150mm	6um
DM-90011D	0-200mm	7um
DM-90012D	0-300mm	9um
Measuring Rod ϕ 4.5mm Base Length: 101.5mm		

Graduation : 0.01mm

Interchangeable hardened steel anvil

■ Depth Micrometer (Digital)

For measuring depth, height, thickness, and steps.



DM-9001E

Model No.	Measuring Range	Accuracy
DM-9001E	0-25mm	±3um
DM-9002E	0-50mm	±3um
DM-9003E	0-100mm	±4um
DM-9004E	0-150mm	±5um
DM-9005E	0-200mm	±6um
DM-9006E	0-300mm	±8um
Measuring Rod ϕ 4.5mm Base Length: 63mm		
DM-9007E	0-25mm	±3um
DM-9008E	0-50mm	±3um
DM-9009E	0-100mm	±4um
DM-9010E	0-150mm	±5um
DM-9011E	0-200mm	±6um
DM-9012E	0-300mm	±8um
Measuring Rod ϕ 4.5mm Base Length: 101.5mm		

Resolution 0.001mm/ 0.00005"
 Interchangeable anvil
 IP54 water/dust protection

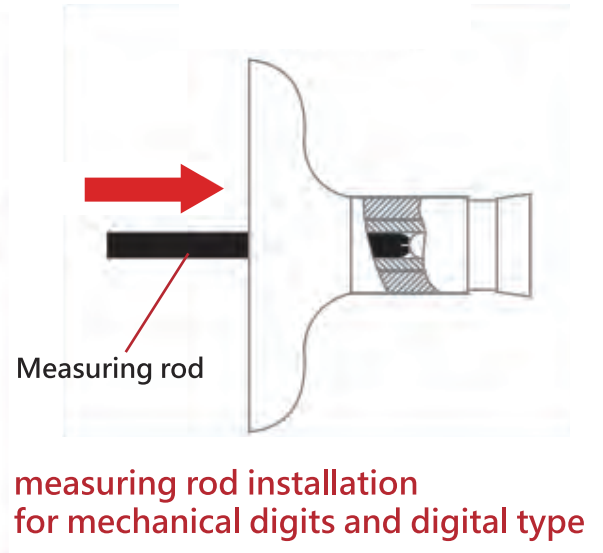
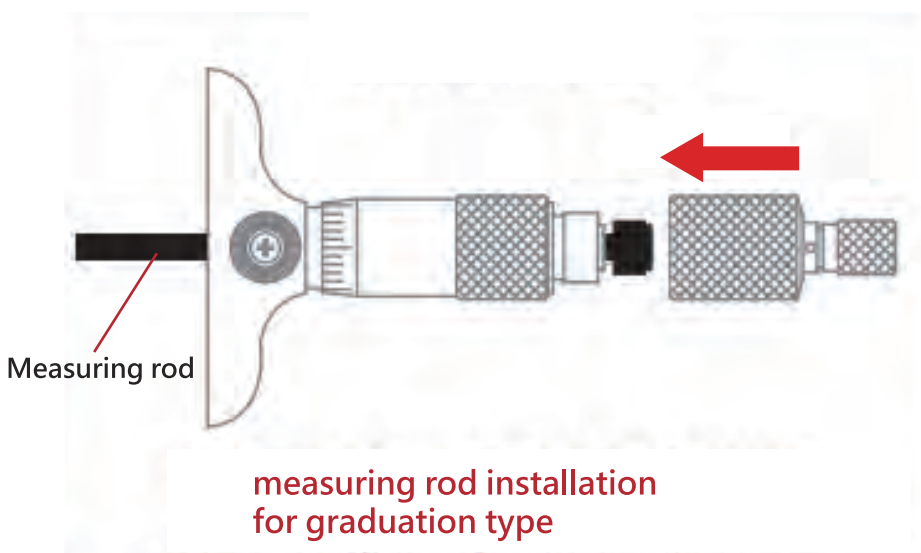

■ Inside Micrometer (Caliper Type)

For measuring inside diameters and dimension of slot width.

Vernier



IM-9002

Model No.	Measuring Range	Accuracy
IM-9001	5-30mm	5um
With ϕ 5mm setting ring gauge		
IM-9002	25-50mm	6um
With ϕ 25mm setting ring gauge		
IM-9003	50-75mm	7um
IM-9004	75-100mm	8um
IM-9005	100-125mm	9um
IM-9006	125-150mm	9um
IM-9007	150-175mm	10um
IM-9008	175-200mm	10um

Graduation : 0.01mm

■ Inside Micrometer (Caliper Type)

For measuring inside diameters and dimension of slot width.

Mechanical Digits

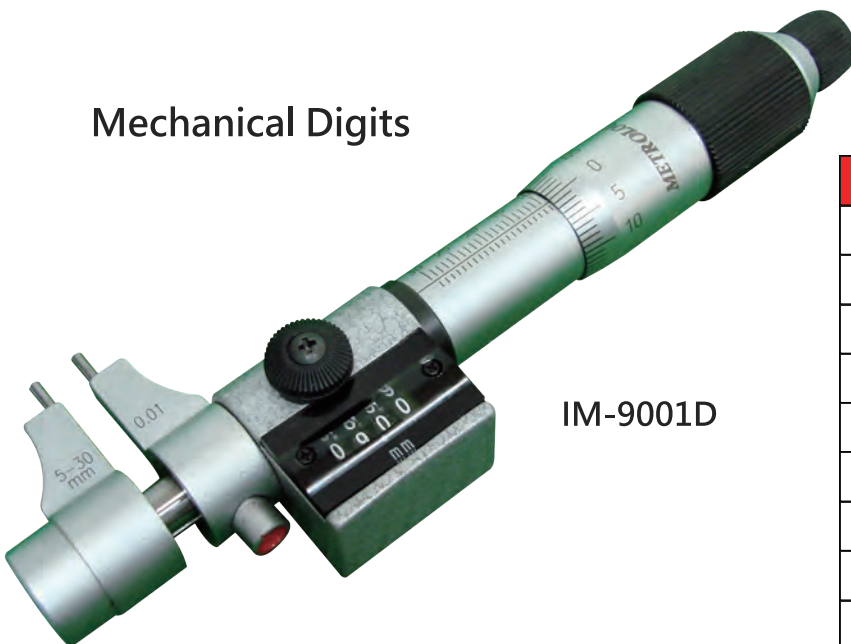

IM-9001D

Model No.	Measuring Range	Accuracy
IM-9001D	5-30mm	5um
With ϕ 5mm setting ring gauge		
IM-9002D	25-50mm	6um
With ϕ 25mm setting ring gauge		
IM-9003D	50-75mm	7um
IM-9004D	75-100mm	8um
IM-9005D	100-125mm	9um
IM-9006D	125-150mm	9um
IM-9007D	150-175mm	10um
IM-9008D	175-200mm	10um

Graduation : 0.01mm

■ Inside Micrometer (Caliper Type)

For measuring inside diameters and dimension of slot width.

Digital

IM-9001E



Model No.	Measuring Range	Accuracy
IM-9001E	5-30mm	±4um
With ϕ 5mm setting ring gauge		
IM-9002E	25-50mm	±5um
With ϕ 25mm setting ring gauge		
IM-9003E	50-75mm	±6um
IM-9004E	75-100mm	±7um
IM-9005E	100-125mm	±8um
IM-9006E	125-150mm	±8um
IM-9007E	150-175mm	±9um
IM-9008E	175-200mm	±9um

Resolution : 0.001mm/ 0.00005"

■ Jaw Type



5-30mm
 Φ 2mm Tungsten carbide measuring jaws



25mm above
 R12mm Tungsten carbide measuring jaws

■ Inside Micrometer (Interchangeable Rod)

For measuring large inside diameters and dimension of slot width.

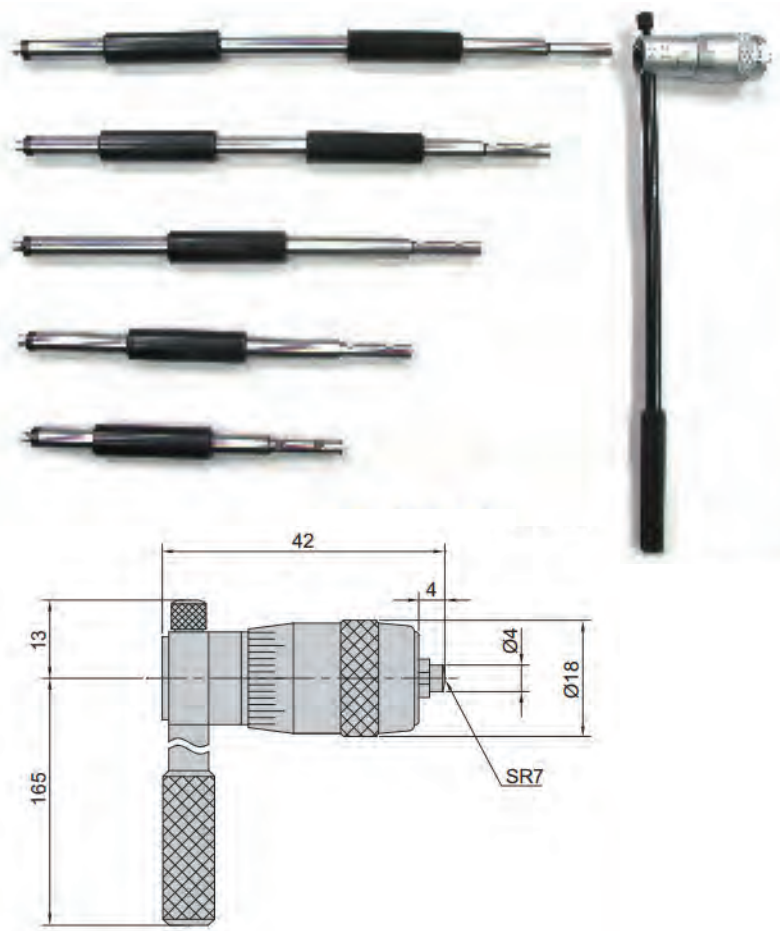

Model No.	Measuring Range	Accuracy
IM-9009	50-200mm	6um
IM-9010	50-300mm	8um
IM-9011	200-500mm	10um
IM-9012	200-1000mm	15um
<i>With Micrometer head & rod (Set)</i>		
IM-9013	25-32mm	4um
IM-9014	25-50mm	4um
IM-9009A	50-63mm	4um
IM-9011A	200-225mm	7um
<i>Micrometer head</i>		

Graduation : 0.01mm

■ Inside Micrometer (Extension Rod Type)

For measuring large inside diameters and dimension of slot width.

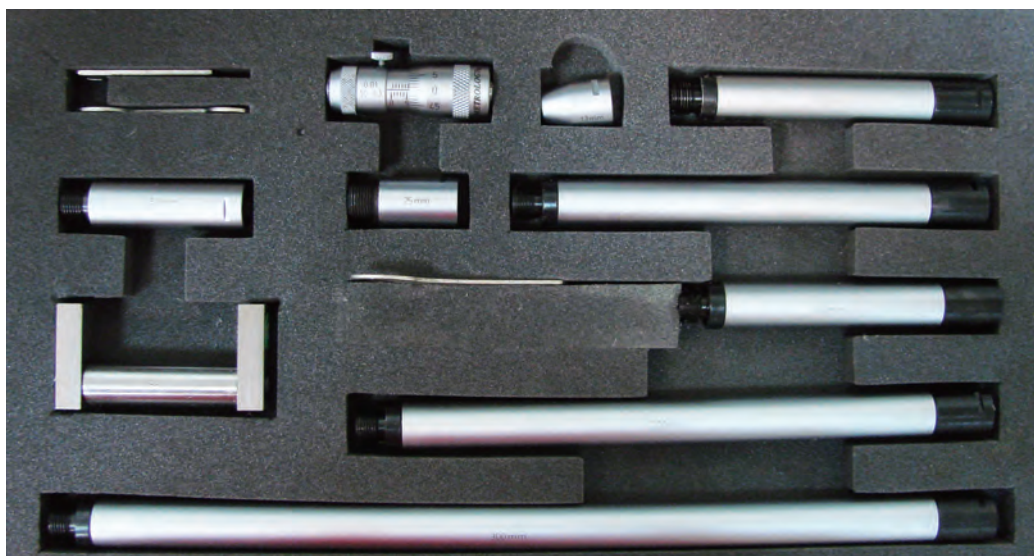

■ Inside Micrometer (Extension Rod Type)

For measuring large inside diameters and dimension of slot width.

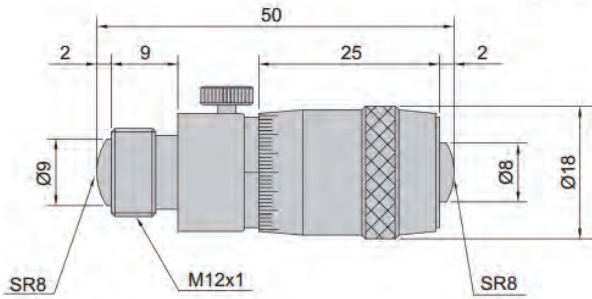

IM-9015 Micrometer head

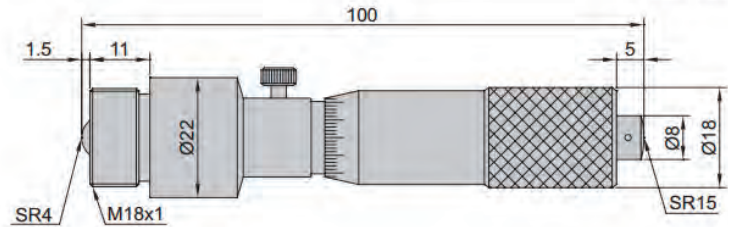

IM-9022 Micrometer head

Model No.	Measuring Range	Accuracy	Micrometer Head & Rod
IM-9015	50-63mm	4um	Micrometer Head only.
IM-9016	50-100mm	4um	13.25mm
IM-9017	50-150mm	5um	13.25.50mm
IM-9018	50-300mm	8um	13.25.50*2.100mm
IM-9019	50-500mm	10um	13.25.50*2.100.200
IM-9020	50-1000mm	20um	13.25.50.100*2.150.200.300mm
IM-9021	50-1500mm	30um	13.25.50.100*2.150.200*2.300*2
IM-9022	100-125mm	5um	Micrometer Head only.
IM-9023	100-500mm	10um	25.50.100.200mm
IM-9024	100-900mm	18um	25.50.100.200.400mm
IM-9025	100-1300mm	25um	25.50.100.200.400*2
IM-9026	100-1700mm	35um	25.50.100.200.400*3
IM-9027	100-2100mm	40um	25.50.100.200.400*4

Graduation : 0.01mm

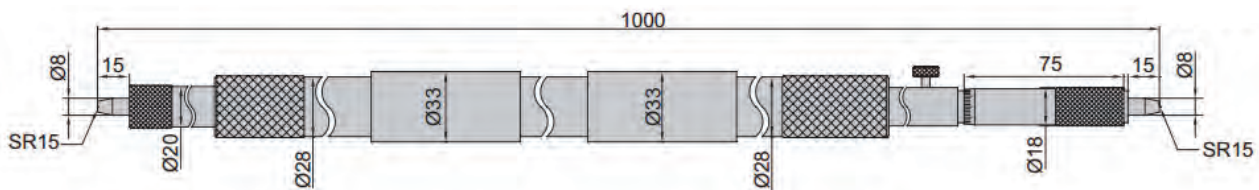

IM-9028 Micrometer head

Model No.	Measuring Range	Accuracy	Micrometer Head & Rod
IM-9028	1000-1050mm	15um	Micrometer Head only
IM-9029	1000-2000mm	40um	50.100*2.200.500
IM-9030	1000-3000mm	50um	50.100*2.200.500.1000
IM-9031	1000-4000mm	60um	50.100*2.200.500.1000*2
IM-9032	1000-5000mm	70um	50.100*2.200.500.1000*3

Graduation : 0.01mm

■ Inside Micrometer (Single Rod)

For measuring inside diameter and distance of slot.



IM-9039

Model No.	Measuring Range	Accuracy
IM-9037	50-75mm	4um
IM-9038	75-100mm	4um
IM-9039	100-125mm	5um
IM-9040	125-150mm	5um
IM-9041	150-175mm	6um
IM-9042	175-200mm	6um
IM-9043	200-225mm	7um
IM-9044	225-250mm	7um
IM-9045	250-275mm	8um
IM-9046	275-300mm	8um
IM-9047	300-325mm	9um
IM-9048	325-500mm	9um
IM-9049	350-375mm	9um
IM-9050	375-400mm	9um
IM-9051	400-425mm	10um
IM-9052	425-450mm	10um
IM-9053	450-475mm	10um
IM-9054	475-500mm	10um
IM-9055	500-525mm	11um
IM-9056	525-550mm	11um

Model No.	Measuring Range	Accuracy
IM-9057	550-575mm	11um
IM-9058	575-600mm	11um
IM-9059	600-625mm	12um
IM-9060	625-650mm	12um
IM-9061	650-675mm	12um
IM-9062	675-700mm	12um
IM-9063	700-725mm	13um
IM-9064	725-750mm	13um
IM-9065	750-775mm	13um
IM-9066	775-800mm	13um
IM-9067	800-825mm	14um
IM-9068	825-850mm	14um
IM-9069	850-875mm	14um
IM-9070	875-900mm	14um
IM-9071	900-925mm	15um
IM-9072	925-950mm	15um
IM-9073	950-975mm	15um
IM-9074	975-1000mm	15um

Graduation : 0.01mm

■ Three Point Inside Micrometer (Vernier)

For measuring inside diameters of lathe, grindings, boring machining.



Standard setting ring gauge

■ Anvil styles (Vernier, Digital, Pistol Grip)



Hardened steel

6-12mm Through hole design
H: 1.6mm



Carbide anvil

12-50mm through hole
and blind hole design



Carbide anvil

50-100mm through hole
and blind hole design

■ Three Point Inside Micrometer (Vernier)



Model No.	Measuring Range	Accuracy	Remark (Set)
TP-9006	6-8mm	3um	With micrometer · Ring gauge ϕ 6mm
TP-9008	8-10mm	3um	With micrometer · Ring gauge ϕ 8mm
TP-9010	10-12mm	3um	With micrometer · Ring gauge ϕ 10mm
TP-9012	12-16mm	4um	With micrometer · Ring gauge ϕ 16mm
TP-9016	16-20mm	4um	With micrometer · Ring gauge ϕ 16mm
TP-9020	20-25mm	4um	With micrometer · Ring gauge ϕ 25mm
TP-9025	25-30mm	4um	With micrometer · Ring gauge ϕ 25mm
TP-9030	30-40mm	5um	With micrometer · Ring gauge ϕ 40mm
TP-9040	40-50mm	5um	With micrometer · Ring gauge ϕ 40mm
TP-9050	50-63mm	6um	With micrometer · Ring gauge ϕ 62mm
TP-9062	62-75mm	6um	With micrometer · Ring gauge ϕ 62mm
TP-9075	75-88mm	6um	With micrometer · Ring gauge ϕ 87mm
TP-9087	87-100mm	6um	With micrometer · Ring gauge ϕ 87mm

Model No.	Measuring Range	Accuracy	Remark (Full set)
TP-01S	6-12mm	3um	Micrometer*3 · Extension rod L:100 · Ring gauge ϕ 8&10mm
TP-02S	12-20mm	4um	Micrometer *2 · Extension rod L: 150 · Ring gauge ϕ 16mm
TP-03S	20-30mm	4um	Micrometer *2 · Extension rod L: 150 · Ring gauge ϕ 25mm
TP-04S	30-50mm	5um	Micrometer *2 · Extension rod L: 150 · Ring gauge ϕ 40mm
TP-05S	50-100mm	6um	Micrometer *4 · Extension rod L: 150 · Ring gauge ϕ 62&87mm



■ Three Point Inside Micrometer (Digital)

For measuring inside diameters of lathe, grindings, boring machining.



TP-9006E



TP-9016E



TP-9050E



EX-05
150mm
Extension rod

Model No.	Measuring Range	Accuracy	Remark (Set)
TP-9006E	6-8mm	3um	With micrometer 、 Ring gauge φ 6mm
TP-9008E	8-10mm	3um	With micrometer 、 Ring gauge φ 8mm
TP-9010E	10-12mm	3um	With micrometer 、 Ring gauge φ 10mm
TP-9012E	12-16mm	4um	With micrometer 、 Ring gauge φ 16mm
TP-9016E	16-20mm	4um	With micrometer 、 Ring gauge φ 16mm
TP-9020E	20-25mm	4um	With micrometer 、 Ring gauge φ 25mm
TP-9025E	25-30mm	4um	With micrometer 、 Ring gauge φ 25mm
TP-9030E	30-40mm	5um	With micrometer 、 Ring gauge φ 40mm
TP-9040E	40-50mm	5um	With micrometer 、 Ring gauge φ 40mm
TP-9050E	50-63mm	6um	With micrometer 、 Ring gauge φ 62mm
TP-9062E	62-75mm	6um	With micrometer 、 Ring gauge φ 62mm
TP-9075E	75-88mm	6um	With micrometer 、 Ring gauge φ 87mm
TP-9087E	87-100mm	6um	With micrometer 、 Ring gauge φ 87mm

Resolution : 0.001mm / 0.00005"

■ Three Point Inside Micrometer (Digital)

Model No.	Measuring Range	Accuracy	Remark (Full set)
TP-01EFS	6-12mm	3um	Micrometer *3、Extension rod L: 100、Ring gauge φ 8&10mm
TP-02EFS	12-20mm	4um	Micrometer *2、Extension rod L: 150、Ring gauge φ 16mm
TP-03EFS	20-30mm	4um	Micrometer *2、Extension rod L: 150、Ring gauge φ 25mm
TP-04EFS	30-50mm	5um	Micrometer *2、Extension rod L: 150、Ring gauge φ 40mm
TP-05EFS	50-100mm	6um	Micrometer *4、Extension rod L: 150、Ring gauge φ 62mm φ 87mm

Resolution : 0.001mm / 0.00005"

■ Digital Reading Head

Suitable for 6-100mm range 3 point measuring heads.

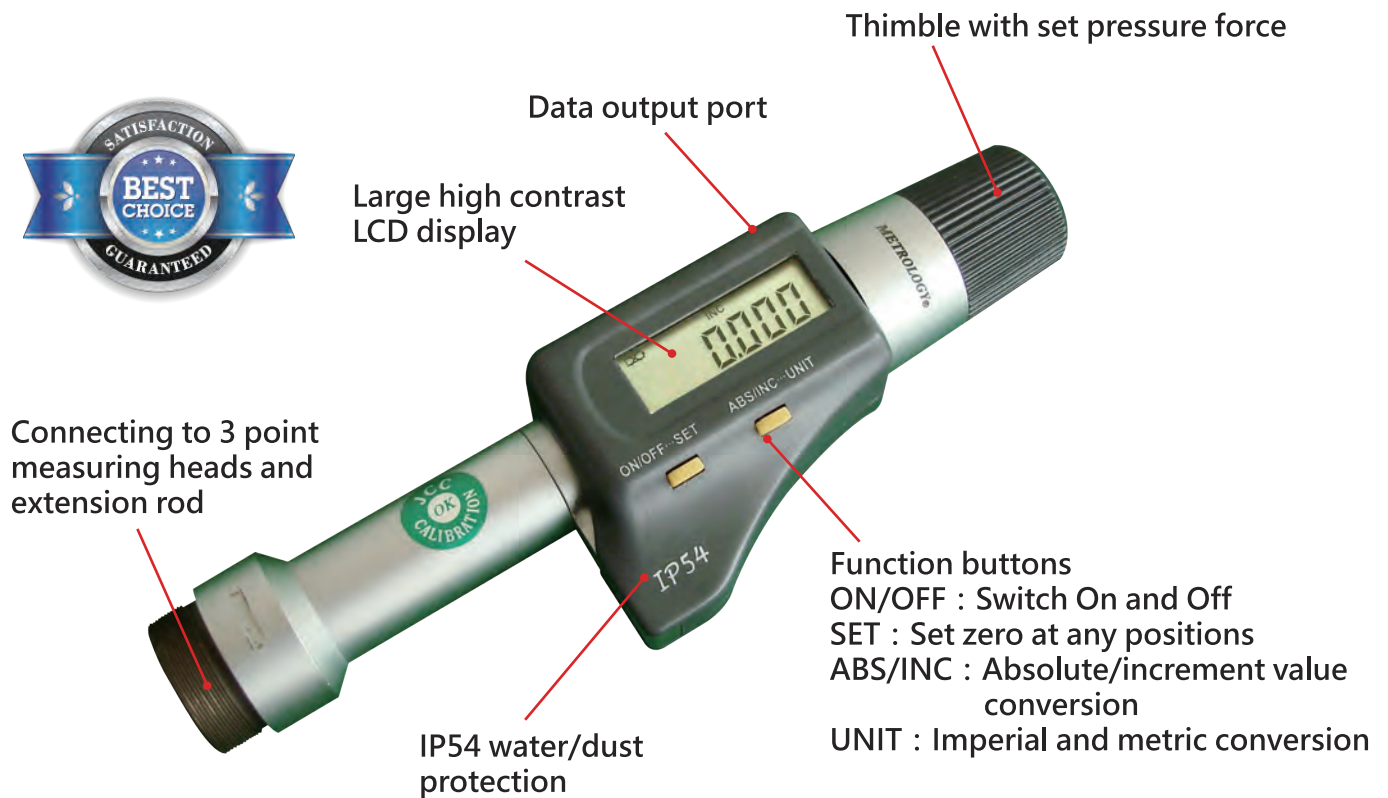

Model No.	Measuring Range
TP-01EMH	For 6-12mm use
TP-02EMH	For 12-20mm use
TP-03EMH	For 20-30mm use
TP-04EMH	For 30-50mm use
TP-05EMH	For 50-100mm use



TP-01EMH

Resolution : 0.001mm / 0.00005"

This product does not include measuring heads、extension rod、setting ring gauge

■ Three Point Inside Micrometer (Pistol-Grip)

For measuring inside diameters of lathe, grindings, boring machining.

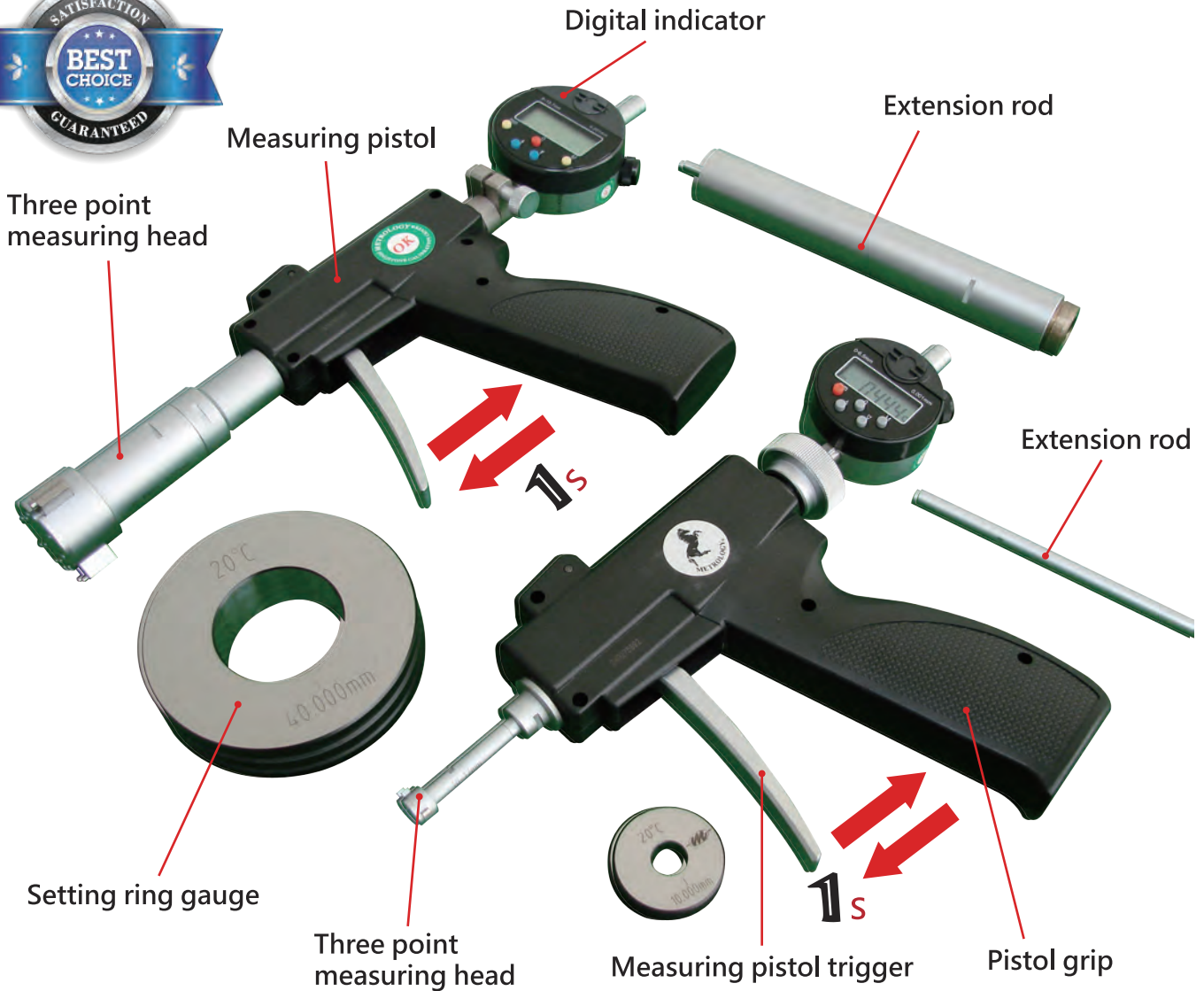

■ Indicators (Optional Purchase)

Resolution : 0.001mm / 0.00005"

ED-9007H (small bezel)

ED-9012H

ED-9013HA (rotatable bezel)



Travel : 0~6.5mm
Suitable range : 6~30mm



Travel : 0~12.7mm
Suitable range : 6-100mm



Travel : 0~13mm
Suitable range : 6-100mm

■ Three Point Inside Micrometer (Pistol-Grip)

For measuring inside diameters of lathe, grindings, boring machining.



Model No.	Measuring Range	Accuracy	Set
TP-9006P	6-8mm	3um	With pistol grip · Measuring head · Ring gauge ϕ 6mm
TP-9008P	8-10mm	3um	With pistol grip · Measuring head · Ring gauge ϕ 8mm
TP-9010P	10-12mm	3um	With pistol grip · Measuring head · Ring gauge ϕ 10mm
TP-9012P	12-16mm	4um	With pistol grip · Measuring head · Ring gauge ϕ 16mm
TP-9016P	16-20mm	4um	With pistol grip · Measuring head · Ring gauge ϕ 16mm
TP-9020P	20-25mm	4um	With pistol grip · Measuring head · Ring gauge ϕ 25mm
TP-9025P	25-30mm	4um	With pistol grip · Measuring head · Ring gauge ϕ 25mm
TP-9030P	30-40mm	5um	With pistol grip · Measuring head · Ring gauge ϕ 40mm
TP-9040P	40-50mm	5um	With pistol grip · Measuring head · Ring gauge ϕ 40mm
TP-9050P	50-63mm	6um	With pistol grip · Measuring head · Ring gauge ϕ 62mm
TP-9062P	62-75mm	6um	With pistol grip · Measuring head · Ring gauge ϕ 62mm
TP-9075P	75-88mm	6um	With pistol grip · Measuring head · Ring gauge ϕ 87mm
TP-9087P	87-100mm	6um	With pistol grip · Measuring head · Ring gauge ϕ 87mm

Remark: Above without dial indicator.

Model No.	Measuring Range	Accuracy	Full set
TP-9001PS	6-12mm	3um	With pistol grip · Measuring head *3 Extension rod L: 100 · Ring gauge ϕ 8&10mm
TP-9002PS	12-20mm	4um	With pistol grip · Measuring head *2 Extension rod L: 150 · Ring gauge ϕ 16mm
TP-9003PS	20-30mm	4um	With pistol grip · Measuring head *2 Extension rod L: 150 · Ring gauge ϕ 25mm
TP-9004PS	30-50mm	5um	With pistol grip · Measuring head *2 Extension rod L: 150 · Ring gauge ϕ 40mm
TP-9005PS	50-100mm	6um	With pistol grip · Measuring head *4 Extension rod L: 150 · Ring gauge ϕ 62&87mm

Remark: Above without dial indicator.

■ Measuring Pistol

For measuring range 6-100mm 3 point micrometer head.



TP-01SG



TP-03SG



TP-05SG

Model No.	Measuring Range
TP-01SG	For 6-12mm use (without dial indicator)
TP-02SG	For 12-20mm use (without dial indicator)
TP-03SG	For 20-30 mm use (without dial indicator)
TP-04SG	For 30-50 mm use (without dial indicator)
TP-05SG	For 50-100 mm use (without dial indicator)

This product does not include indicator · measuring heads · extension rod · setting ring gauge



■ Extension Rod

For all kind of three point micrometer.



Model No.	Length	Measuring Range
EX-01	L: 100mm	For 6-12mm use
EX-02	L: 150mm	For 12-20mm use
EX-03	L: 150mm	For 20-30mm use
EX-04	L: 150mm	For 30-50mm use
EX-05	L: 150mm	For 50-100mm use

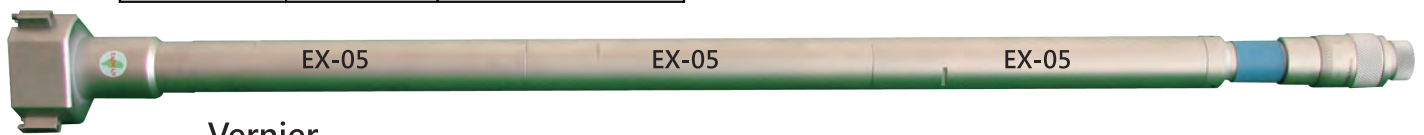

Vernier



Digital

■ Three Point Micrometer (Long Travel)

For measuring inside diameters of lathe, grindings, boring machining.



Vernier
Graduation : 0.001mm

Digital
Resolution 0.001mm/ 0.00005"



■ Vernier Diagram

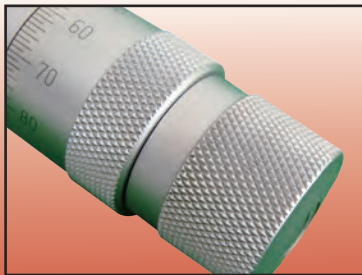

Ratchet stop

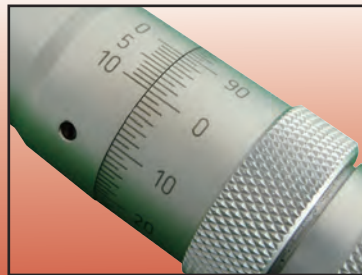

Micro Parallax Free

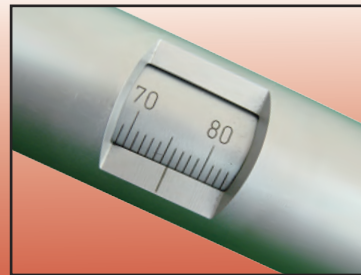

Main graduation

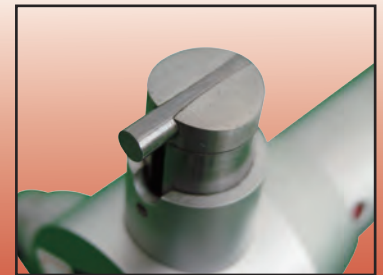

Blind hole type tungsten carbide anvil

Model No. (Vernier)	Model No. (Digital)	Measuring Range (mm)	Accuracy (um)	Remark
TP-9050L	TP-9050EL	50-70	5	Micrometer · ring gauge ϕ 50mm
TP-9070L	TP-9070EL	70-100	6	Micrometer · ring gauge ϕ 70mm
TP-9100L	TP-9100EL	100-150	7	Micrometer · ring gauge ϕ 100mm
TP-9150L	TP-9150EL	150-250	8	Micrometer · ring gauge ϕ 150mm
TP-9200L	TP-9200EL	200-300	10	Micrometer · ring gauge ϕ 200mm



Digital function button

Micrometer Head

Application

The micrometer heads are instrumental in electronic components manufacturing such as semiconductors, wafer, positioning machinery, optical component alignment equipment, X-Y table positioning, machine tools, fixtures, special gage, and other equipment where precise movement and adjustment are required.

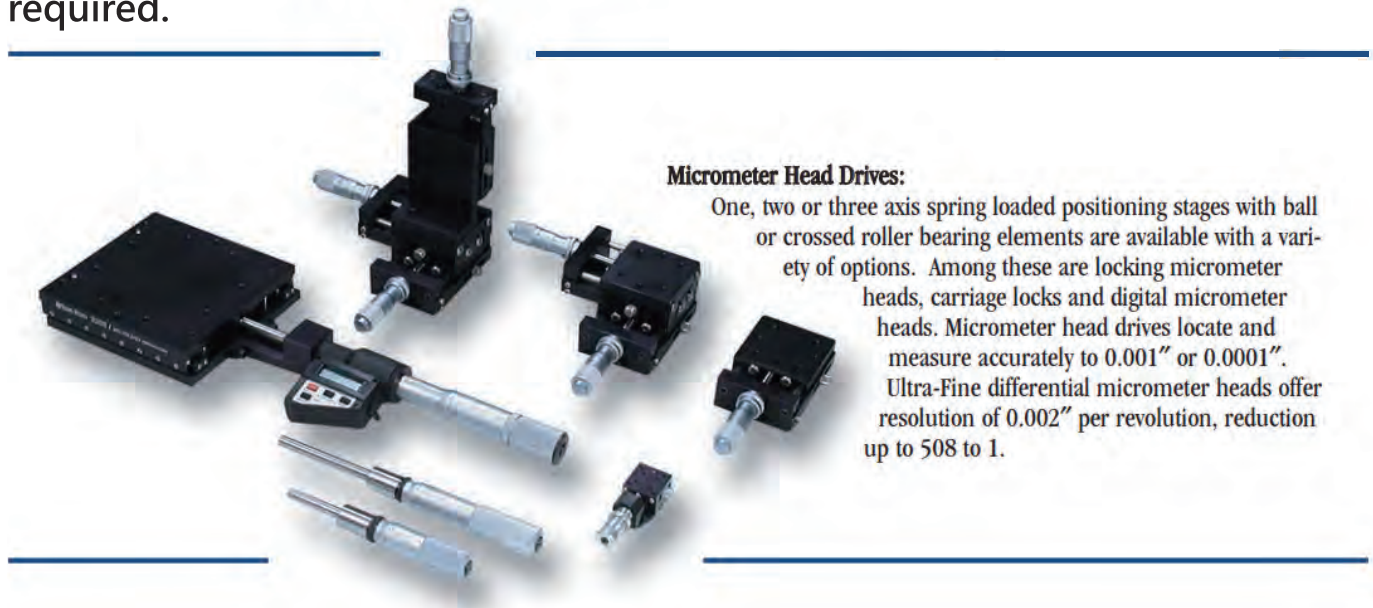

Micrometer Head Drives:

One, two or three axis spring loaded positioning stages with ball or crossed roller bearing elements are available with a variety of options. Among these are locking micrometer heads, carriage locks and digital micrometer heads. Micrometer head drives locate and measure accurately to 0.001" or 0.0001". Ultra-Fine differential micrometer heads offer resolution of 0.002" per revolution, reduction up to 508 to 1.



Special Heads

Jingstone Metrology also design and manufactured many special types of micrometer heads for widely diversified applications that require micrometer accuracy in setting and adjustment.

The micrometer can be customized to suit your particular requirements in wide choice of sizes, range and graduation.

We design and build to your special needs. So if you do not see what you need, please feel free to contact us.

Micrometer Head



Features (Vernier)

- German technic unibody precision screw and spindle.
- Non-glare satin chrome finish on thimble and sleeve. Laser engraved graduation.
- Precision grinded and fine-polished tungsten carbide measuring face and hardened steel stem.



Features (Digital)

- High contrast digital LCD display, for easy readability, reducing vision error.
- German technic unibody precision screw and spindle.
- Non-glare satin chrome finish on thimble and sleeve. Laser engraved graduation.
- Precision grinded and fine-polished tungsten carbide measuring face and hardened steel stem.

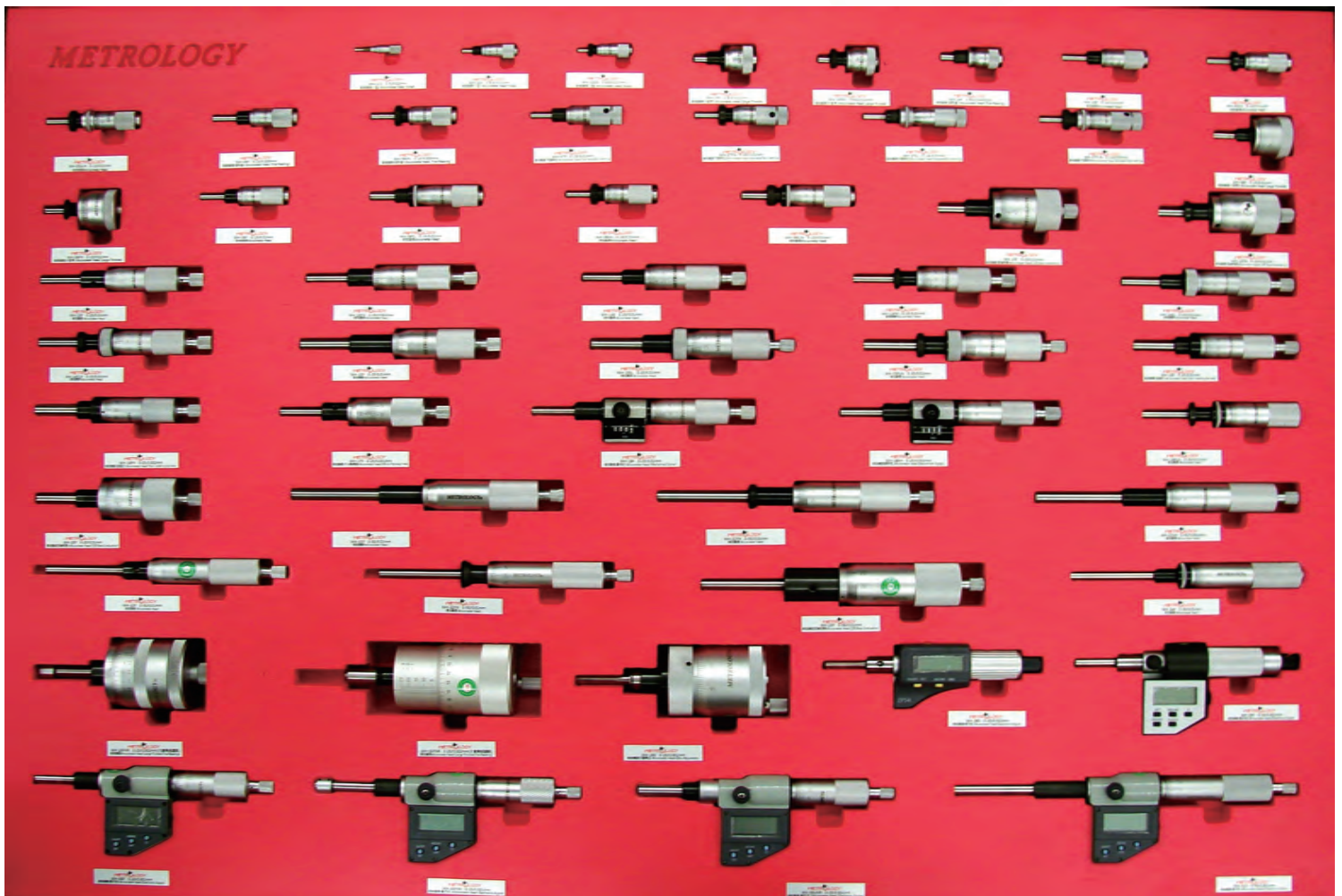

Micrometer Head (Digital)

- Large high contrast LCD display for easy readability, reducing vision errors.
- Unibody hardened steel Ø 6.5mm spindle. Automatic pressure force thimble.
- Precision grinded and fine- polished tungsten carbide measuring face, Ø 9.52mm clamp stem. 3V battery (1 year)
- Function: manual on/off switch, ABS/INC value conversion, set zero, metric/imperial value conversion, auto-off after 5 min idle.



Model No.	Measuring Range	Accuracy
MH-28E	0-25mm/0-1"	±0.003mm

Resolution : 0.001mm / 0.00005"

Micrometer Head (Digital)

- Large high contrast LCD display for easy readability, reducing vision errors.
- Black cast iron frame. Non-glare satin chrome thimble and sleeve. Ring type spindle lock.
- Unibody hardened steel Ø 6.5mm spindle. 3V battery (1 year)
- Precision grinded and fine- polished tungsten carbide measuring face, Ø 9.52mm clamp stem, 3/8" clamp nut and spindle lock.
- Function: manual on/off switch, ABS/INC value conversion, set zero, metric/imperial value conversion, auto-off after 10 min idle.



Model No.	Measuring Range	Accuracy
MH-30E	0-25mm/0-1"	±0.003mm
MH-31E	0-50mm/0-2"	±0.004mm

Resolution : 0.001mm / 0.00005"



Micrometer Head (Vernier)

- German technic unibody precision screw and spindle.
- Non-glare satin chrome finish on thimble and sleeve. Laser engraved graduation.
- Precision grinded and fine- polished tungsten carbide measuring face and hardened steel clamp stem.

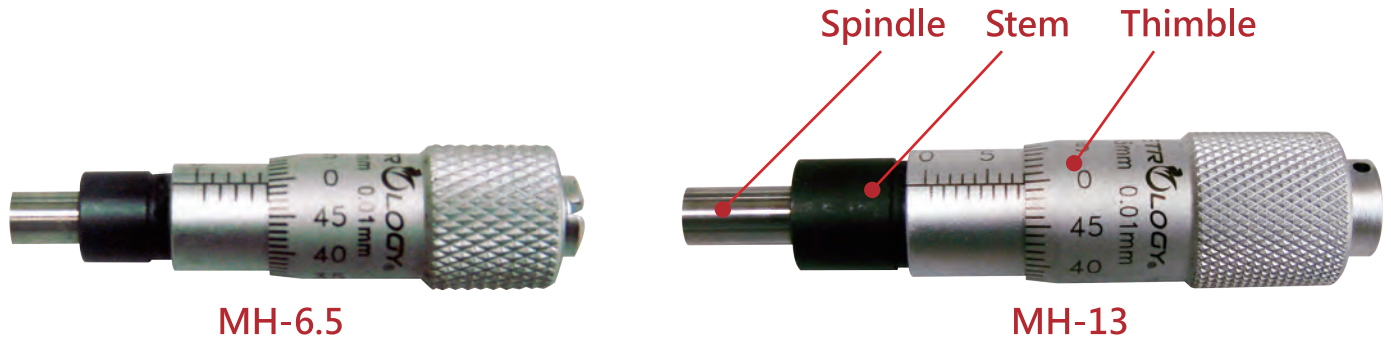

Model No.	Measuring Range	Spindle Diameter	Stem Diameter	Overall Length	Thimble Diameter	Accuracy (um)
MH-6.5	0-6.5mm	Φ3.5mm	Φ6mm	L:37mm	Φ9.5mm	4
MH-13	0-13mm	Φ5 mm	Φ9.5 mm	L:59 mm	Φ13.4 mm	4
MH-25	0-25mm	Φ6.5 mm	Φ10 mm (With clamp nut)	L:98 mm	Φ18.2 mm	4
MH-50	0-50mm	Φ6.5 mm	Φ10 mm (With clamp nut)	L:146 mm	Φ18.2 mm	5

Graduation : 0.01mm

■ Micrometer Head (Small)



MH-01F

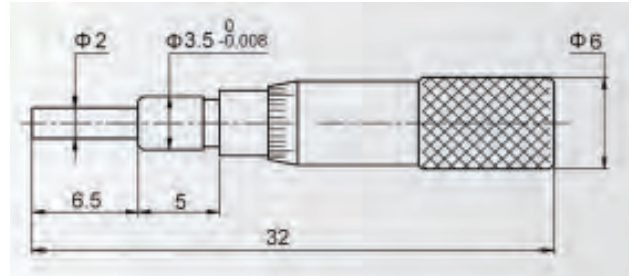

MH-01F



MH-02F

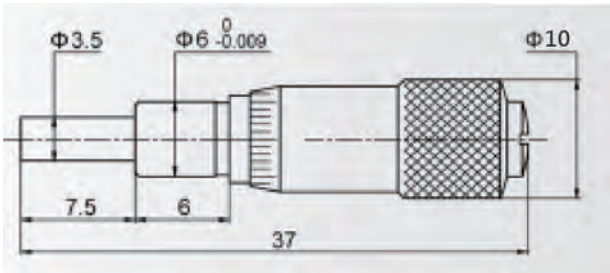

MH-02F

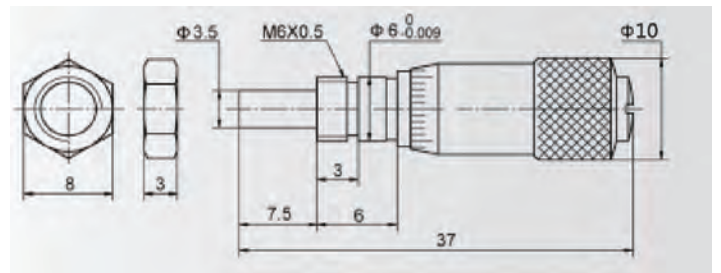

MH-02FN

Model No.	Measuring Range	Accuracy	Remark
MH-01F	0-5mm	4um	Flat measuring face
MH-01S			Spherical measuring face
Graduation : 0.02 mm			
MH-02F	0-6.5mm	4um	Flat measuring face
MH-02S			Spherical measuring face
MH-02FN			Flat measuring face with clamp nut
MH-02SN			Spherical measuring face with clamp nut
Graduation : 0.01 mm			

■ Micrometer Head (Large Thimble)

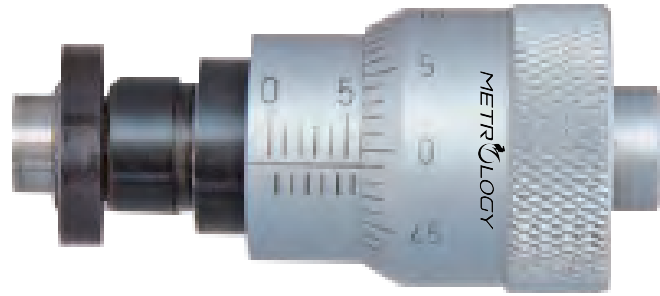

MH-03FN

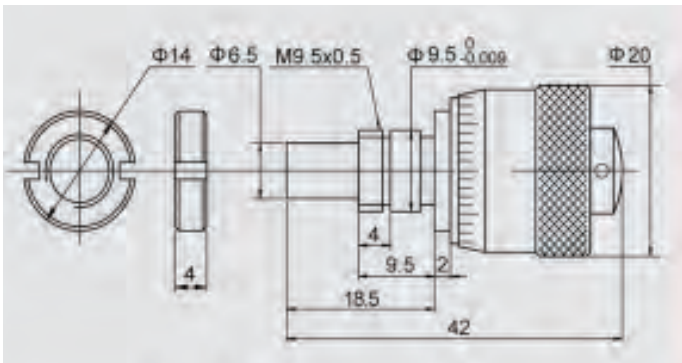

MH-03FN

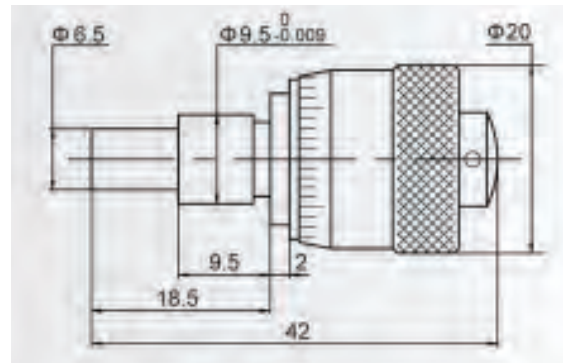

MH-03F

Model No.	Measuring Range	Accuracy	Remark
MH-03F	0-6.5mm	4um	Flat measuring face
MH-03S			Spherical measuring face
MH-03FN			Flat measuring face with clamp nut
MH-03SN			Spherical measuring face with clamp nut

Graduation : 0.01mm

■ Micrometer Head (Fine Reading)



MH-04F

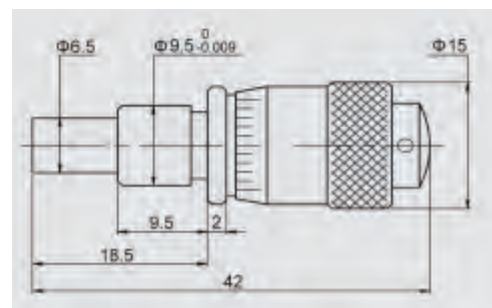

MH-04F

Model No.	Measuring Range	Accuracy	Remark
MH-04F	0-6.5mm	4um	Flat measuring face
MH-04S			Spherical measuring face

Graduation : 0.005mm

■ Micrometer Head



MH-05FLN



MH-05F

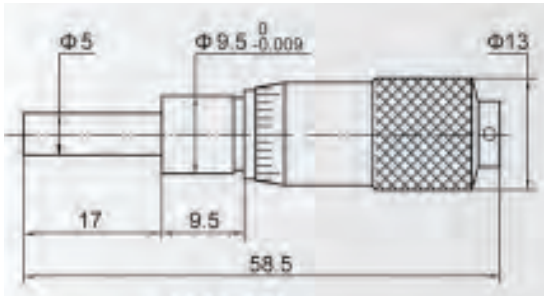

MH-05F

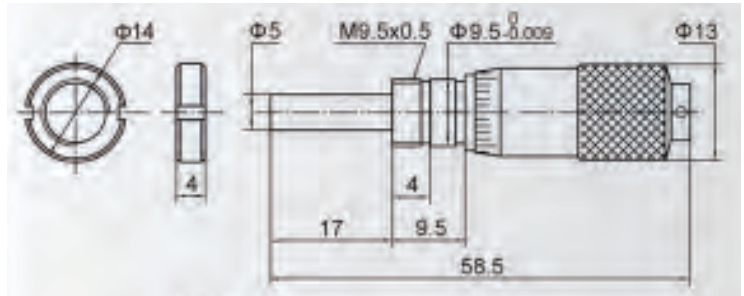

MH-05FN

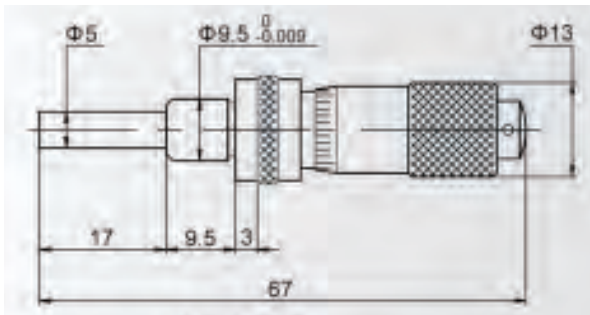

MH-05FL

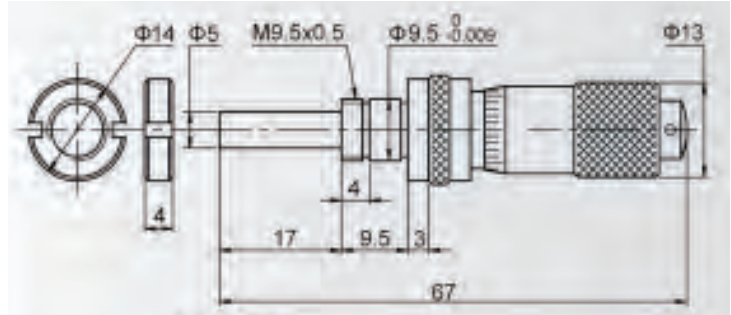

MH-05FLN

Model No.	Measuring Range	Accuracy	Remark
MH-05F	0-13mm	4um	Flat measuring face
MH-05S			Spherical measuring face
MH-05FN			Flat measuring face with clamp nut
MH-05SN			Spherical measuring face with clamp nut
MH-05FL			Flat measuring face with spindle lock
MH-05SL			Spherical measuring face with spindle lock
MH-05FLN			Flat measuring face with spindle lock, clamp nut
MH-05SLN			Spherical measuring face with spindle lock, clamp nut

Graduation : 0.01mm

■ Micrometer Head (Fine Reading)



MH-06S

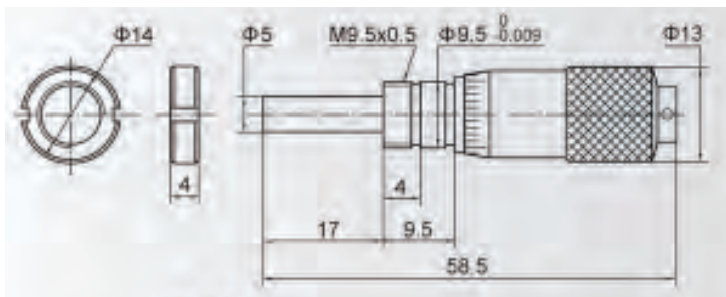

MH-06FN

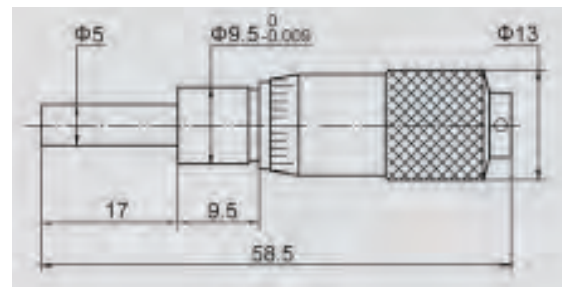

MH-06F

Model No.	Measuring Range	Accuracy	Remark
MH-06F	0-13mm	4um	Flat measuring face
MH-06S			Spherical measuring face
MH-06FN			Flat measuring face with clamp nut
MH-06SN			Spherical measuring face with clamp nut

Graduation : 0.005mm Screw pitch : 0.25mm

■ Micrometer Head (Variable Zero Settings)



MH-07F

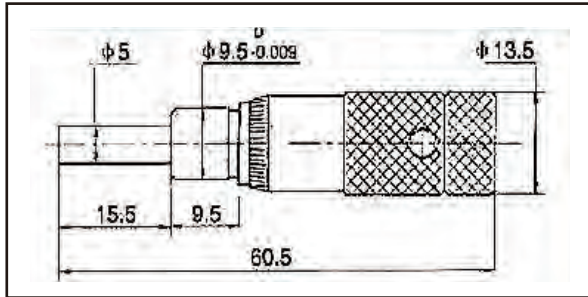

MH-07F

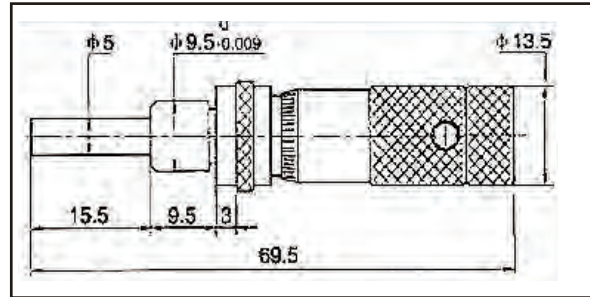

MH-07FL

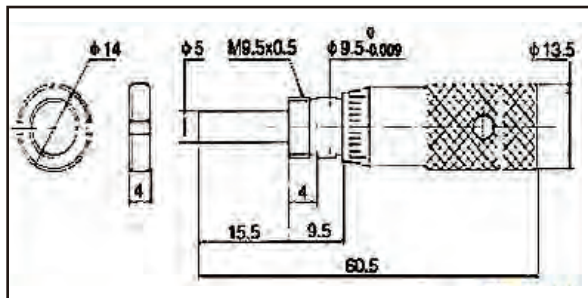

MH-07FN

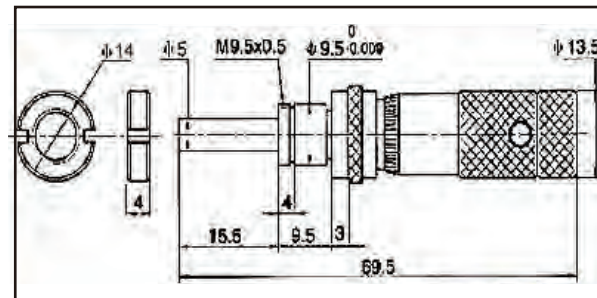

MH-07FLN

Model No.	Measuring Range	Accuracy	Remark
MH-07F	0-13mm	4um	Flat measuring face
MH-07S			Spherical measuring face
MH-07FN			Flat measuring face with clamp nut
MH-07SN			Spherical measuring face with clamp nut
MH-07FL			Flat measuring face with spindle lock
MH-07SL			Spherical measuring face with spindle lock
MH-07FLN			Flat measuring face with spindle lock, clamp nut
MH-07SLN			Spherical measuring face with spindle lock, clamp nut

Graduation : 0.01mm

■ Micrometer Head (Large Thimble)



MH-08FN

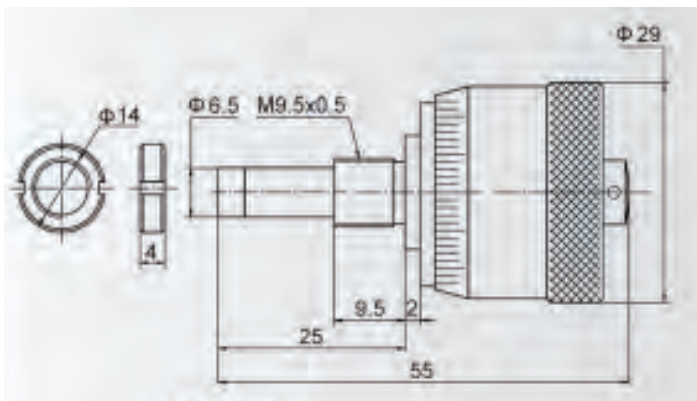

MH-08FN

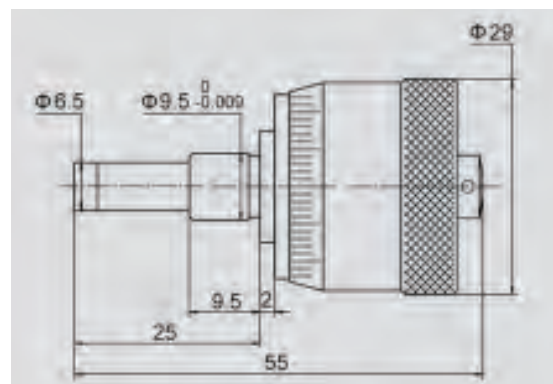

MH-08F

Model No.	Measuring Range	Accuracy	Remark
MH-08F	0-13mm	4um	Flat measuring face
MH-08S			Spherical measuring face
MH-08FN			Flat measuring face with clamp nut
MH-08SN			Spherical measuring face with clamp nut

Graduation : 0.01mm

■ Micrometer Head



MH-09FL



MH-09S

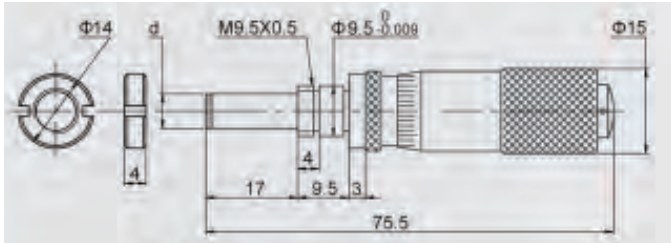

MH-09FLN

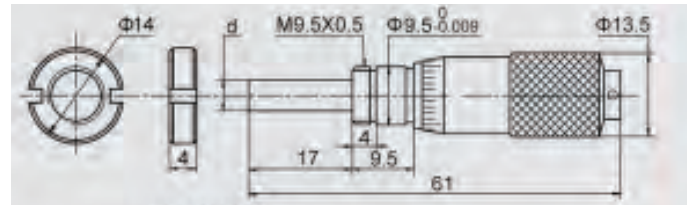

MH-09FN

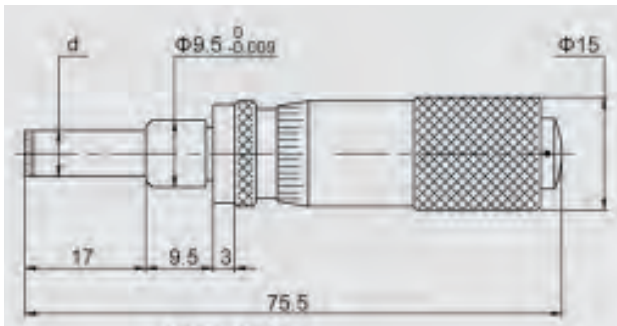

MH-09FL

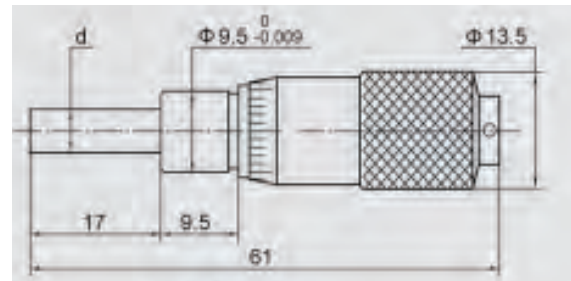

MH-09F

Model No.	Measuring Range	Accuracy	Remark
MH-09F	0-15mm	4um	Flat measuring face
MH-09S			Spherical measuring face
MH-09FN			Flat measuring face with clamp nut
MH-09SN			Spherical measuring face with clamp nut
MH-09FL			Flat measuring face with spindle lock
MH-09SL			Spherical measuring face with spindle lock
MH-09FLN			Flat measuring face with spindle lock, clamp nut
MH-09SLN			Spherical measuring face with spindle lock, clamp nut

Graduation : 0.01mm

■ Micrometer Head (100 Step Graduation)



MH-10F

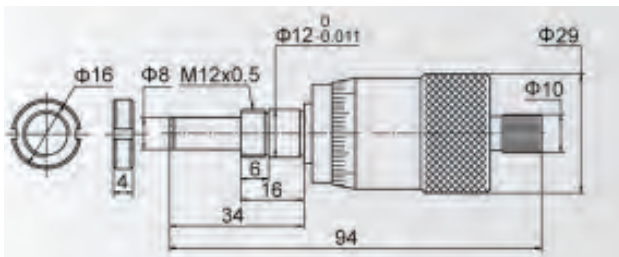

MH-10FN

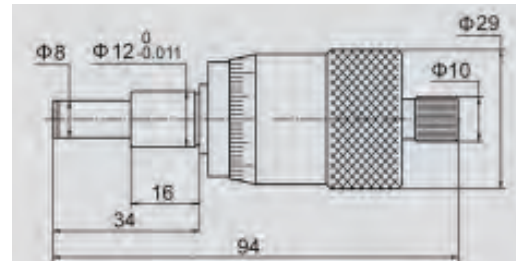

MH-10F

Model No.	Measuring Range	Accuracy	Remark
MH-10F	0-15mm	4um	Flat measuring face
MH-10S			Spherical measuring face
MH-10FN			Flat measuring face with clamp nut
MH-10SN			Spherical measuring face with clamp nut

Graduation : 0.01mm

■ Micrometer Head



MH-13F

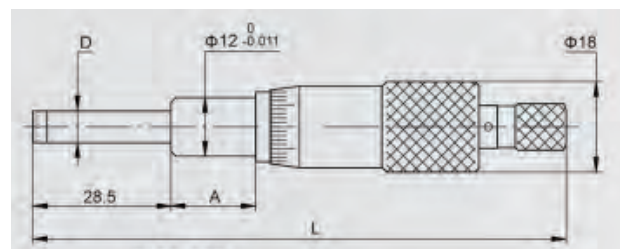

MH-13F

Model No.	Measuring Range	Accuracy	Remark
MH-13F	0-25mm	4um	Flat measuring face
MH-13S			Spherical measuring face
Graduation : 0.01 mm			
MH-13FH	0-25mm	3um	Flat measuring face
MH-13SH			Spherical measuring face
Graduation : 0.002 mm			

■ Micrometer Head



MH-14F

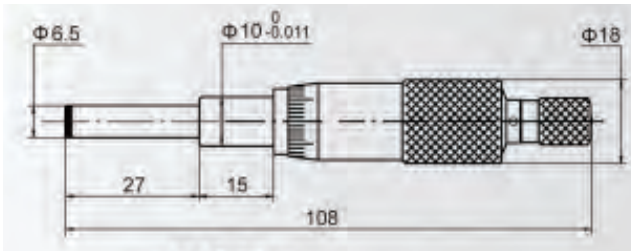

MH-14F

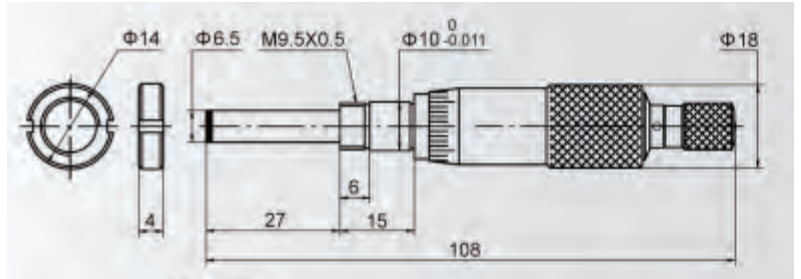

MH-14FN

Model No.	Measuring Range	Accuracy	Remark
MH-14F	0-25mm	4um	Flat measuring face
MH-14S			Spherical measuring face
MH-14FN			Flat measuring face with clamp nut
MH-14SN			Spherical measuring face with clamp nut

Graduation : 0.01mm

■ Micrometer Head



MH-15F

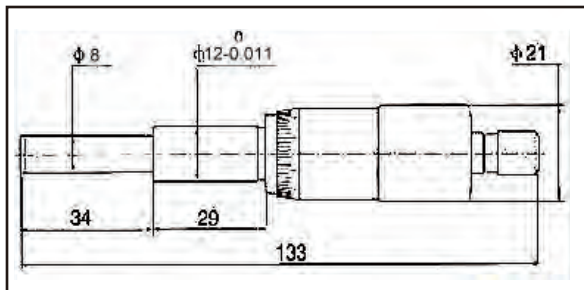

MH-15F

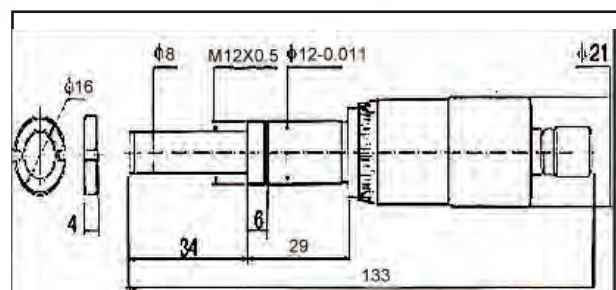

MH-15FN

Model No.	Measuring Range	Accuracy	Remark
MH-15F	0-25mm	4um	Flat measuring face
MH-15S			Spherical measuring face
MH-15FN			Flat measuring face with clamp nut
MH-15SN			Spherical measuring face with clamp nut

Graduation : 0.01mm

■ Micrometer Head (Non-Rotating Spindle)



Non-rotating spindle

MH-16F

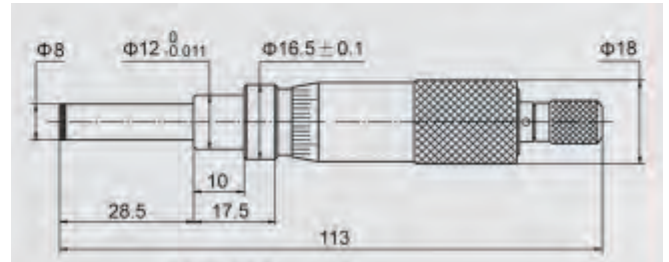

MH-16F

Model No.	Measuring Range	Accuracy	Remark
MH-16F	0-25mm	4um	Flat measuring face
MH-16S			Spherical measuring face
Graduation : 0.01 mm			
MH-16FH	0-25mm	3um	Flat measuring face
MH-16SH			Spherical measuring face
Graduation : 0.002 mm			

■ Micrometer Head (Micro Parallax Free)



MH-17F

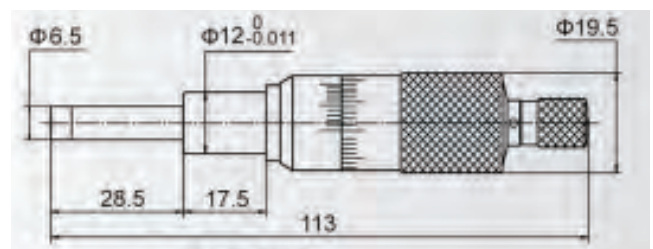

MH-17F

Model No.	Measuring Range	Accuracy	Remark
MH-17F	0-25mm	3um	Flat measuring face
MH-17S			Spherical measuring face

Graduation : 0.001mm

■ Micrometer Head (Mechanical Digits)



MH-18F

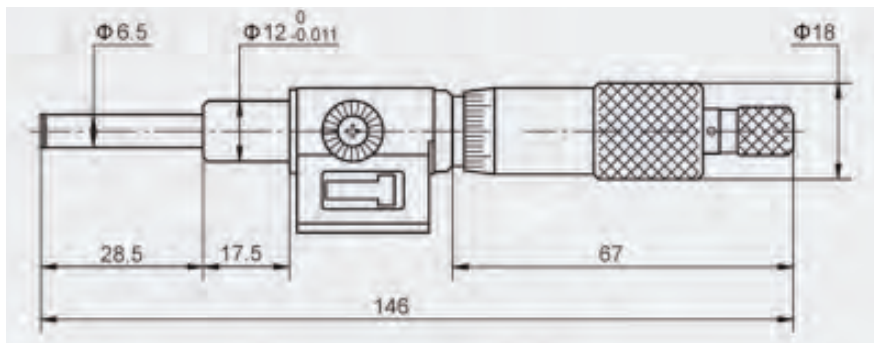

MH-18F

Model No.	Measuring Range	Accuracy	Remark
MH-18F	0-25mm	4um	Flat measuring face
MH-18S			Spherical measuring face
Graduation : 0.01 mm			
MH-18FH	0-25mm	3um	Flat measuring face
MH-18SH			Spherical measuring face
Graduation : 0.002 mm			

■ Micrometer Head



MH-19FLN

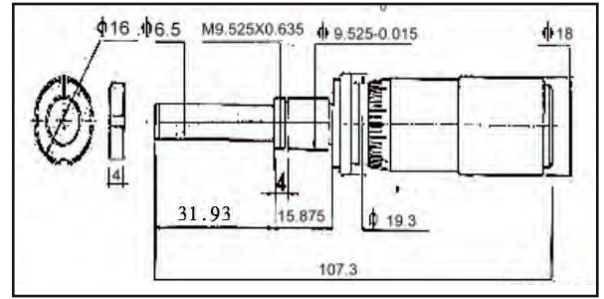

MH-19FLN

Model No.	Measuring Range	Accuracy	Remark
MH-19F	0-25mm	4um	Flat measuring face
MH-19FLN			Flat measuring face with spindle lock, clamp nut

Graduation : 0.01mm

■ Micrometer Head (100 Step Graduation)



MH-20F

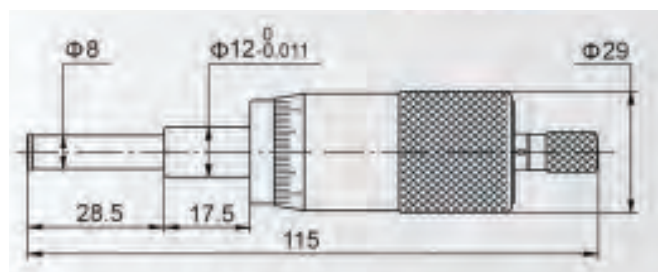

MH-20F

Model No.	Measuring Range	Accuracy	Remark
MH-20F	0-25mm	4um	Flat measuring face
MH-20S			Flat measuring face with spindle lock, clamp nut

Graduation : 0.01mm

■ Micrometer Head (Long Travel)



MH-21F

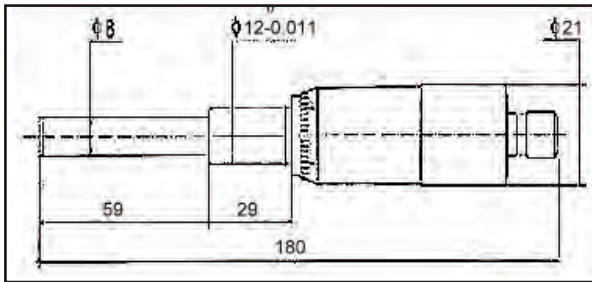

MH-21F

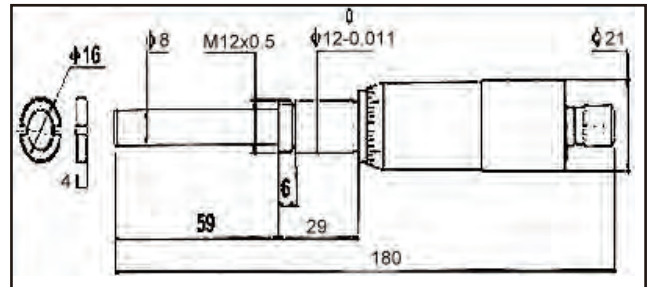

MH-21FN

Model No.	Measuring Range	Accuracy	Remark
MH-21F	0-50mm	5um	Flat measuring face
MH-21S			Spherical measuring face
MH-21FN			Flat measuring face with clamp nut
MH-21SN			Spherical measuring face with clamp nut
Graduation : 0.01 mm			
MH-21FH	0-50mm	4um	Flat measuring face
MH-21SH			Spherical measuring face
MH-21FNH			Flat measuring face with clamp nut
MH-21SNH			Spherical measuring face with clamp nut
Graduation : 0.001 mm			

■ Micrometer Head (Long Travel)



MH-22F

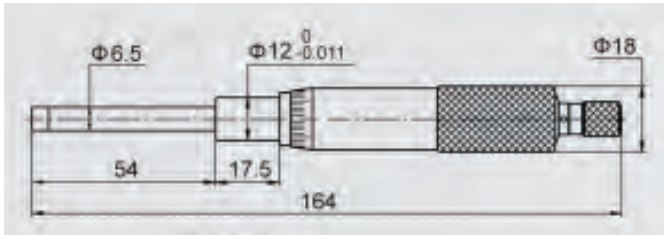

MH-22F

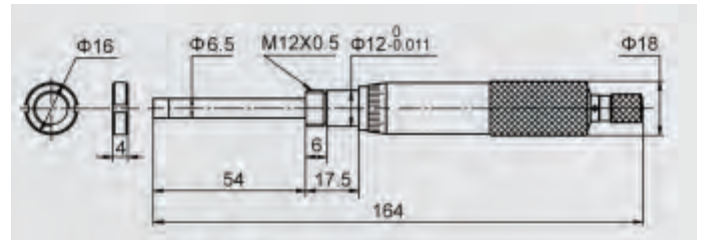

MH-22FN

Model No.	Measuring Range	Accuracy	Remark
MH-22F	0-50mm	5um	Flat measuring face
MH-22S			Spherical measuring face
MH-22FN			Flat measuring face with clamp nut
MH-22SN			Spherical measuring face with clamp nut

Graduation : 0.01mm

■ Micrometer Head (100 Step Graduation)

 1mm per revolution



MH-23S

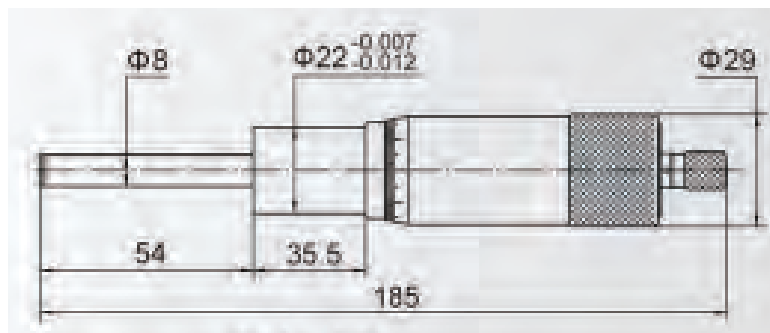

MH-23F

Model No.	Measuring Range	Accuracy	Remark
MH-23F	0-50mm	5um	Flat measuring face
MH-23S			Spherical measuring face

Graduation : 0.01mm

■ Micrometer Head



MH-24FLN

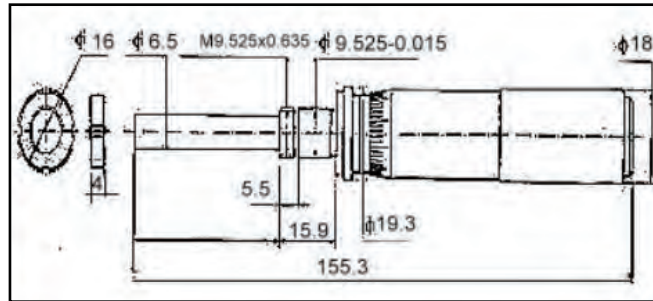

MH-24FLN

Model No.	Measuring Range	Accuracy	Remark
MH-24FL	0-50mm	5um	Flat measuring face with spindle lock
MH-24FLN			Flat measuring face with spindle lock ,clamp nut

Graduation : 0.01mm

■ Micrometer Head (Large Thimble Fine Graduation)

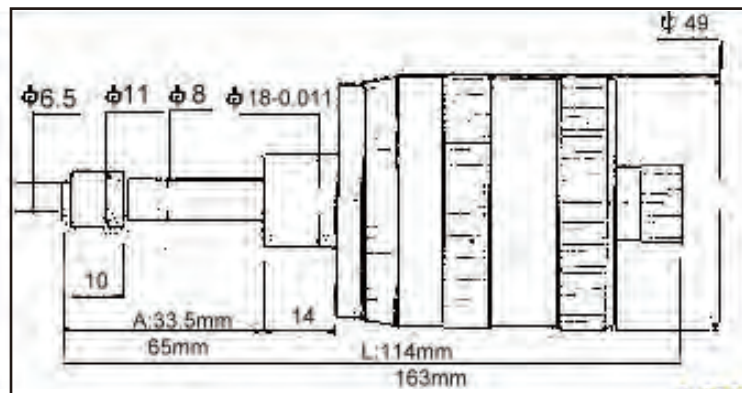

MH-25FNR

Model No.	Measuring Range	Accuracy	Remark
MH-25F	0-25mm	3um	Flat measuring face
MH-25FNR			Flat measuring face 、 non-rotating device
MH-50F	0-50mm	5um	Flat measuring face
MH-50FNR			Flat measuring face 、 non-rotation device

Graduation : 0.002mm Bi-directional graduation

■ Micrometer Head (Digital)



MH-28F

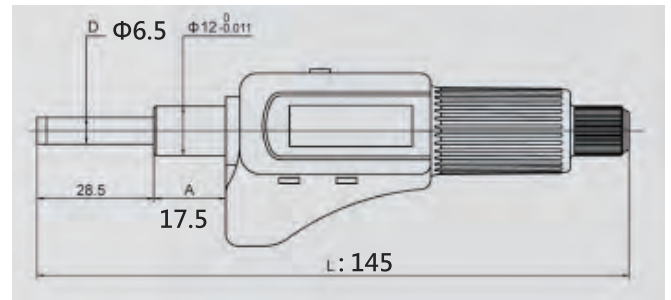

MH-28F

Model No.	Measuring Range	Accuracy	Remark
MH-28F	0-25mm/1"	$\pm 3\mu\text{m}$	Flat measuring face · IP54 water-proof
MH-28S			Spherical measuring face · IP54 water-proof
Function: on/off, set, ABS/INC, mm/in, data output, ratchet friction thimble, measuring force			

Resolution : 0.001mm / 0.00005"

■ Micrometer Head (Digital)



MH-29F

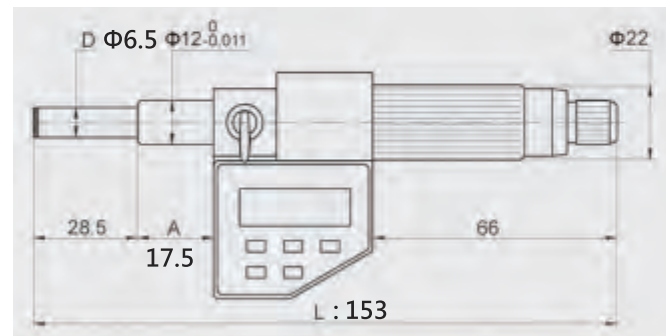

MH-29F

Model No.	Measuring Range	Accuracy	Remark
MH-29F	0-25mm/1"	$\pm 3\mu\text{m}$	Flat measuring face · IP54 water-proof
MH-29S			Spherical measuring face · IP54 water-proof
Function: on/off, set, ABS/INC, mm/in, data output			

Resolution : 0.001mm / 0.00005"

■ Micrometer Head (Digital)



MH-30F

MH-31F

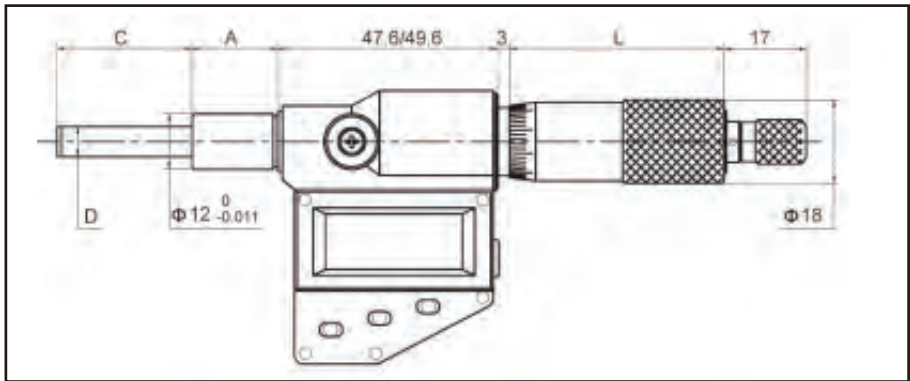

Measuring Rang	A	C	D	L
0-25mm	17.5mm	28.5mm	Φ6.5mm	47mm
0-50mm	35.5mm	53mm	Φ7.5mm	71.5mm

Model No.	Measuring Range	Accuracy	Remark
MH-30F	0-25mm / 1"	±3um	Flat measuring face · IP54 water-proof
MH-30S			Spherical measuring face · IP54 water-proof
MH-30FN			Flat measuring face with clamp nut · IP54 water-proof
MH-30SN			Spherical measuring face with clamp nut · IP54 water-proof
MH-30FNR			Flat measuring face · non-rotating spindle · IP54 water-proof
MH-30UNR			Universal interchangeable anvil · non-rotating device · IP54 water-proof
MH-31F	0-50mm / 2"	±4um	Flat measuring face · IP54 water-proof
MH-31S			Spherical measuring face · IP54 water-proof

Function: on/off, set, ABS/INC, unit, data output, ratchet stop measuring force

Resolution : 0.001mm / 0.00005"

■ Micrometer Head (IP65 Fast)

Rotating spindle



2 mm per revolution



MH-32F

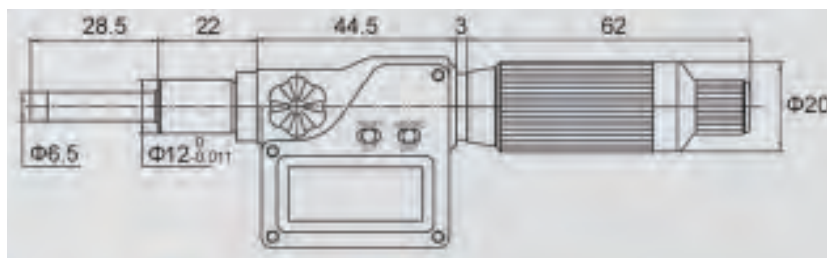

MH-32F

Model No.	Measuring Range	Accuracy	Remark
MH-32F	0-25mm/1"	±3um	Flat measuring face · rotating spindle
MH-32S			Spherical measuring face · rotating spindle

Resolution : 0.001mm / 0.00005"

■ Micrometer Head (IP65 Fast)

Non-rotating spindle



2 mm per revolution



MH-32FNR

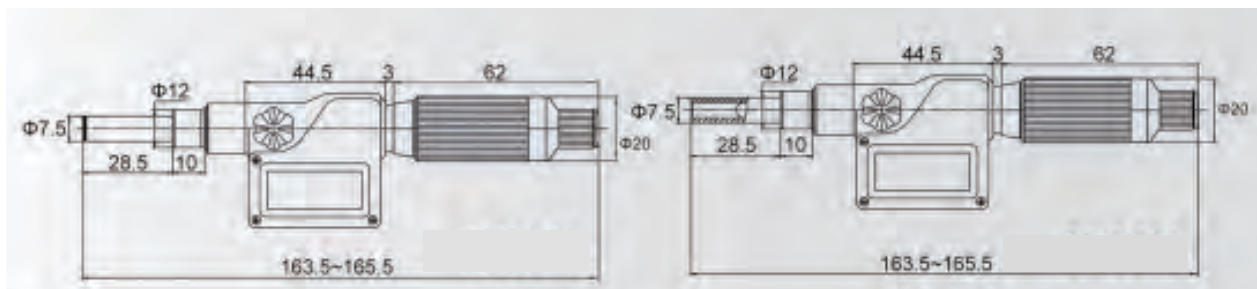

MH-32FNR

MH-32UNR(Universal interchangeable anvil)

Model No.	Measuring Range	Accuracy	Remark
MH-32FNR	0-25mm/1"	±3um	Flat measuring face · non-rotating spindle
MH-32UNR			Universal interchangeable anvil · non-rotating spindle

Resolution : 0.001mm / 0.00005"